



## THE NC-QUIET BY DESIGN

The NC is the result of extensive design studies focused on cooling tower sound control. These studies were complicated by the fact that the cooling tower market is typically driven by one of two powerful, yet often conflicting requirements. The most common is for a cooling tower that provides the required heat rejection capacity with a high level of reliability at low cost. Sound control, while important, is not the primary consideration for this application.

The other requirement, which is becoming ever more important in our crowded, fast-paced society, is driven by conditions that demand the lowest practical sound level. Energy efficiency, reliability, ease of maintenance and reasonable cost, while still extremely important, are not the highest priorities

In the first case, sound is important, while in the second case it is extremely important. To best satisfy these two competing market requirements we created a multi-tiered approach, through key mechanical equipment selections, to sound control. The result is more options than any other cooling tower on the market today.

The result is a line of towers capable of meeting all but the most restrictive noise limitations—and that will react favorably to natural attenuation. Where the tower has been sized to operate within an enclosure, the enclosure itself will have a damping effect on sound. Sound also declines with distance—by about 6 dBA each time the distance doubles.

All standard NC cooling towers are equipped with low sound fans. This in combination with zero-splash crossflow film-fill results in a line of towers capable of meeting most noise limitations. Where noise at a critical point is likely to exceed an acceptable limit, several other options are available—listed below in ascending order of cost impact:

- The Marley "Quiet Package" includes the affordable Quiet Fan mechanical option, optimized to achieve the lowest possible sound levels while maintaining efficiency.
- A Marley Variable Speed Drive automatically minimizes the tower's noise level during periods of reduced load and/or reduced ambient temperature without sacrificing the system's ability to maintain a constant cold water temperature. This is a relatively inexpensive solution, and can pay for itself quickly in reduced energy costs. The natural nighttime reduction in wet-bulb temperature makes this a very feasible solution in most areas of the world. It also eliminates fan cycling. In combination with a Marley Quiet Package, the Marley Variable Speed Drive is capable of meeting all but the most restrictive noise limitations.
- The most extreme cases may require inlet and discharge sound attenuator sections—however, the static pressure loss imposed by discharge attenuators may necessitate an increase in tower size. Two stages of inlet or discharge attenuators supported by the tower and designed and tested for the most stringent requirements are available as an option. See page 24.
- For more severe cases requiring the lowest possible fan sound levels the Marley "Ultra Quiet" fan option is now available on most NC models. Tower height will increase—obtain current sales drawings from your Marley sales representative for accurate dimensions.

The advantage is yours. You now have the choices you need to balance your project's performance, space and cost requirements with your sound level needs for a win-win solution to your cooling system design.

## ENCLOSURES

Occasionally, cooling towers are located inside architectural enclosures for aesthetic reasons. Although NC towers adapt well to enclosures, the designer must realize the potential impact of a poorly arranged enclosure on the tower's performance and operation. The designer must take care to provide generous air inlet paths, and the tower's fan cylinder discharge height should not be lower than the elevation of the top of the enclosure. *Marley Technical Report #H-004 "External Influences on Cooling Tower Performance"* is available at [spxcooling.com](http://spxcooling.com) or from your Marley sales representative.

As suggested in the aforementioned Technical Report, it may also be advisable to specify a design wet-bulb temperature 1°F higher than normal to compensate for potential recirculation initiated by the enclosure. You'll benefit from discussing your project with your Marley sales representative.



Marley "Ultra Quiet" fan

**SYSTEM CLEANLINESS**

Cooling towers are very effective air washers. Atmospheric dust able to pass through the relatively small louver openings will enter the circulating water system. Increased concentrations can intensify system maintenance by clogging screens and strainers—and smaller particulates can coat system heat transfer surfaces. In areas of low flow velocity—such as the cold water basin—sedimentary deposits can provide a breeding ground for bacteria.

In areas prone to dust and sedimentation, you should consider installing some means for keeping the cold water basin clean. Typical devices include side stream filters and a variety of filtration media.

**WATER TREATMENT**

To control the buildup of dissolved solids resulting from water evaporation, as well as airborne impurities and biological contaminants including Legionella, an effective consistent water treatment program is required. Simple blowdown may be adequate to control corrosion and scale, but biological contamination can only be controlled with biocides.

An acceptable water treatment program must be compatible with the variety of materials incorporated in a cooling tower—ideally the pH of the circulating water should fall between 6.5 and 8.0. Batch feeding of chemicals directly into the cooling tower is not a good practice since localized damage to the tower is possible. Specific startup instructions and additional water quality recommendations can be found in the **NC User Manual** which accompanies the tower and also is available from your local Marley sales representative. For complete water treatment recommendations, consult a competent, qualified water treatment supplier.

**⚠ CAUTION**

The cooling tower must be located at such distance and direction to avoid the possibility of contaminated discharge air being drawn into building fresh air intake ducts. The purchaser should obtain the services of a Licensed Professional Engineer or Registered Architect to certify that the location of the cooling tower is in compliance with applicable air pollution, fire and clean air codes.

**TYPICAL APPLICATIONS**

The NC tower is an excellent choice for normal applications requiring cold water for the dissipation of heat. This includes condenser water cooling for air conditioning, refrigeration, and thermal storage systems, as well as their utilization for free-cooling in all of those systems. The NC can also be used in the cooling of jacket water for engines and air compressors, and are widely applied to dissipate waste heat in a variety of industrial, power and manufacturing processes.

Choosing the all stainless steel construction option, the NC can be confidently applied in unusually corrosive processes and operating environments. However, no single product line can answer all problems, and selective judgement should be exercised in the following situations



**APPLICATIONS REQUIRING ALTERNATIVE COOLING TOWER SELECTIONS**

Certain types of applications are incompatible with any cooling tower with film fill—whether NC or a competitive tower of similar manufacture. Film fill is subject to distortion in high water temperatures, and the narrow passages are easily clogged by turbid or debris-laden water. Some of the applications, which call for alternative tower designs are:

- **Ethylene glycol content**—can plug fill passages as slime and algae accumulate to feed on the available organic materials.
- **Fatty acid content**—found in processes such as soap and detergent manufacturing and some food processing—fatty acids pose a serious threat for plugging fill passages.
- **Particulate carry over**—often found in steel mills and cement plants—can both cause fill plugging, and can build up to potentially damaging levels on tower structure.
- **Pulp carry over**—typical of the paper industry and food processing where vacuum pumps or barometric condensers are used. Causes fill plugging which may be intensified by algae.

**ALTERNATIVE SELECTIONS**

In addition to the NC, SPX Cooling Technologies offers a full scope of products in various designs and capacities to meet the special demands of specific applications.

**spxcooling.com**—visit us on the web for a complete list of products, services, publications and to find your nearest sales representative.

NC8401 NC8402 NC8403 NC8405

Use this data for preliminary layouts only. Obtain current drawing from your local Marley sales representative.

**UPDATE™** web-based selection software, available at [spxcooling.com/update](http://spxcooling.com/update) provides NC model recommendations based on customer's specific design requirements.

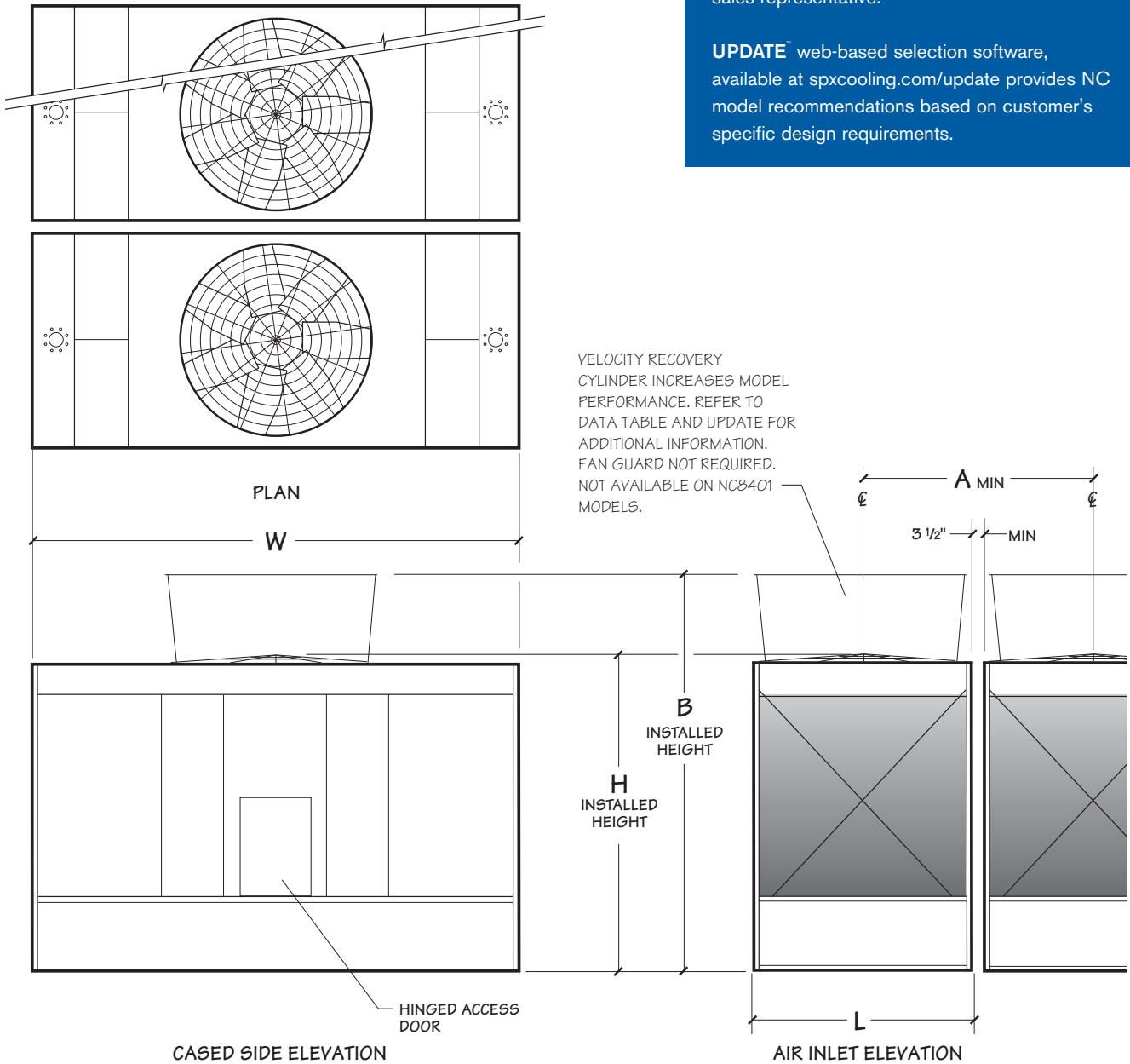

NC8401 NC8402 NC8403 NC8405

Model note 2	Nominal Tons note 3	Nominal Tons with VR Cylinder note 3	Motor hp	Design Operating Weight lb	Shipping Weight lb	Dimensions				
						L	W	H	B	A
NC8401G-1	101	–	2	7810	3983	6'-6 <sup>1</sup> / <sub>4</sub> "	12'-10"	10'-2 <sup>1</sup> / <sub>2</sub> "	–	6'-9 <sup>3</sup> / <sub>4</sub> "
NC8401H-1	117	–	3							
NC8401K-1	139	–	5							
NC8401M-1	159	–	7.5							
NC8401N-1	175	–	10							
NC8401P-1	198	–	15							
NC8402H-1	156	168	3	10171	4748	8'-4 <sup>3</sup> / <sub>4</sub> "	14'-2"	10'-3"	14'-9"	8'-8 <sup>1</sup> / <sub>4</sub> "
NC8402K-1	186	199	5							
NC8402M-1	212	228	7.5							
NC8402N-1	236	252	10							
NC8402P-1	265	283	15							
NC8402Q-1	288	308	20							
NC8403H-1	196	214	3	15812	7411	8'-4 <sup>3</sup> / <sub>4</sub> "	18'-2"	11'-11 <sup>1</sup> / <sub>4</sub> "	16'-5 <sup>1</sup> / <sub>4</sub> "	8'-8 <sup>1</sup> / <sub>4</sub> "
NC8403K-1	237	256	5							
NC8403M-1	269	291	7.5							
NC8403N-1	297	320	10							
NC8403P-1	329	363	15							
NC8403Q-1	370	398	20							
NC8403R-1	391	422	25							
NC8403S-1	420	453	30							
NC8403T-1	448	489	40							
NC8405H-1	242	246	3	19691	8896	9'-10 <sup>3</sup> / <sub>4</sub> "	19'-11"	11'-11 <sup>1</sup> / <sub>4</sub> "	16'-5 <sup>1</sup> / <sub>4</sub> "	10'-2 <sup>1</sup> / <sub>4</sub> "
NC8405K-1	280	292	5							
NC8405M-1	318	332	7.5							
NC8405N-1	354	369	10							
NC8405P-1	403	420	15							
NC8405Q-1	442	461	20							
NC8405R-1	469	491	25							
NC8405S-1	491	513	30							
NC8405T-1	539	565	40							
NC8405U-1	566	591	50							

NOTE

- 1 Use this bulletin for preliminary layouts only. Obtain current drawings from your Marley sales representative. All table data is per cell.
- 2 Last numeral of model number indicates number of cells. Change as appropriate for your selection.
- 3 Nominal tons are based upon 95°F HW, 85°F CW, 78°F WB, 3 gpm/ton and standard low sound fans. The UPDATE web-based selection software provides NC model recommendations based on specific design requirements.
- 4 Standard overflow is a 4" dia. standpipe in the collection basin floor. The standpipe removes for flush-out and draining. See page 20 for side overflow option.
- 5 Outlet sizes vary according to gpm and arrangement. See pages 20 and 21 for outlet sizes and details.
- 6 Makeup water connection may be 1" or 2" dia., depending upon tower heat load, water pressure, and desired connections. See page 15 for additional information.

NC8407 NC8409

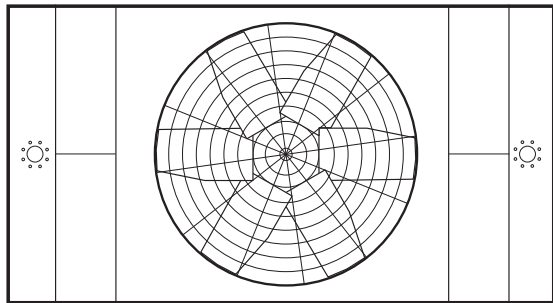
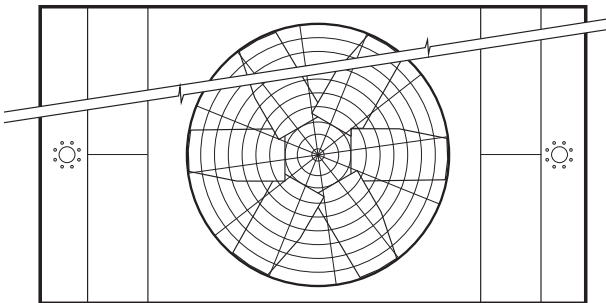

PLAN

W

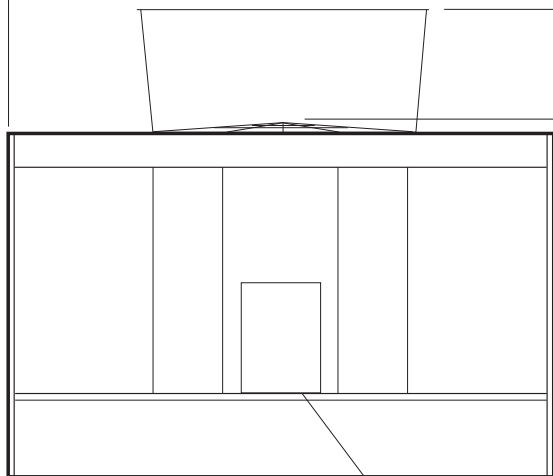

CASED SIDE ELEVATION

HINGED ACCESS DOOR

VELOCITY RECOVERY CYLINDER INCREASES MODEL PERFORMANCE. REFER TO DATA TABLE AND UPDATE FOR ADDITIONAL INFORMATION. FAN GUARD NOT REQUIRED.

Use this data for preliminary layouts only. Obtain current drawing from your local Marley sales representative.

**UPDATE™** web-based selection software, available at [spxcooling.com/update](http://spxcooling.com/update) provides NC model recommendations based on customer's specific design requirements.

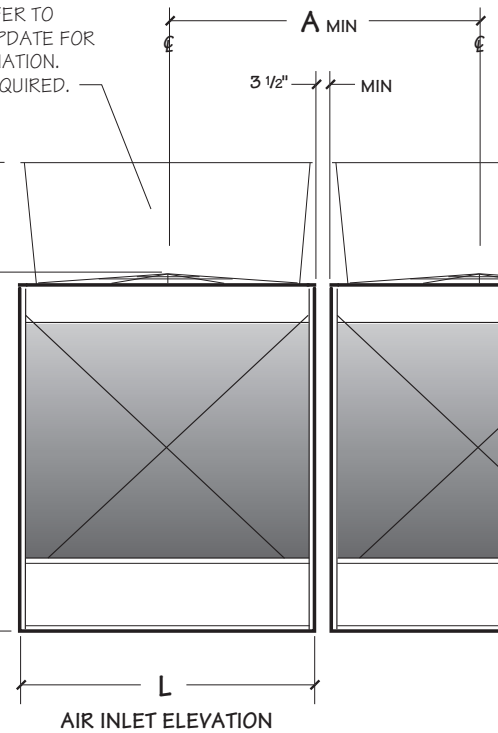

NC8407 NC8409

Model note 2	Nominal Tons note 3	Nominal Tons with VR Cylinder note 3	Motor hp	Design Operating Weight lb	Shipping Weight lb	Dimensions		
						L	W	A
NC8407K-1	320	330	5	24824	11156	11'-10 <sup>3</sup> / <sub>4</sub> "	21'-0"	12'-2 <sup>1</sup> / <sub>4</sub> "
NC8407M-1	365	380	7.5					
NC8407N-1	401	418	10					
NC8407P-1	458	476	15					
NC8407Q-1	500	524	20					
NC8407R-1	540	564	25					
NC8407S-1	571	598	30					
NC8407T-1	623	652	40					
NC8407U-1	670	700	50					
NC8407V-1	703	736	60					
NC8409M-1	417	427	7.5	30129	13176	13'-10 <sup>3</sup> / <sub>4</sub> "	22'-5"	14'-2 <sup>1</sup> / <sub>4</sub> "
NC8409N-1	459	472	10					
NC8409P-1	524	538	15					
NC8409Q-1	575	591	20					
NC8409R-1	617	634	25					
NC8409S-1	650	673	30					
NC8409T-1	715	736	40					
NC8409U-1	768	790	50					
NC8409V-1	808	832	60					
NC8409W-1	841	865	75					

**NOTE**

- 1 Use this bulletin for preliminary layouts only. Obtain current drawings from your Marley sales representative. All table data is per cell.
- 2 Last numeral of model number indicates number of cells. Change as appropriate for your selection.
- 3 Nominal tons are based upon 95°F HW, 85°F CW, 78°F WB, 3 gpm/ton and standard low sound fans. The UPDATE web-based selection software provides NC model recommendations based on specific design requirements.
- 4 Standard overflow is a 4" dia. standpipe in the collection basin floor. The standpipe removes for flush-out and draining. See page 20 for side overflow option.
- 5 Outlet sizes vary according to gpm and arrangement. See pages 20 and 21 for outlet sizes and details.
- 6 Makeup water connection may be 1" or 2" dia., depending upon tower heat load, water pressure, and desired connections. See page 15 for additional information.

NC8410 NC8411 NC8412

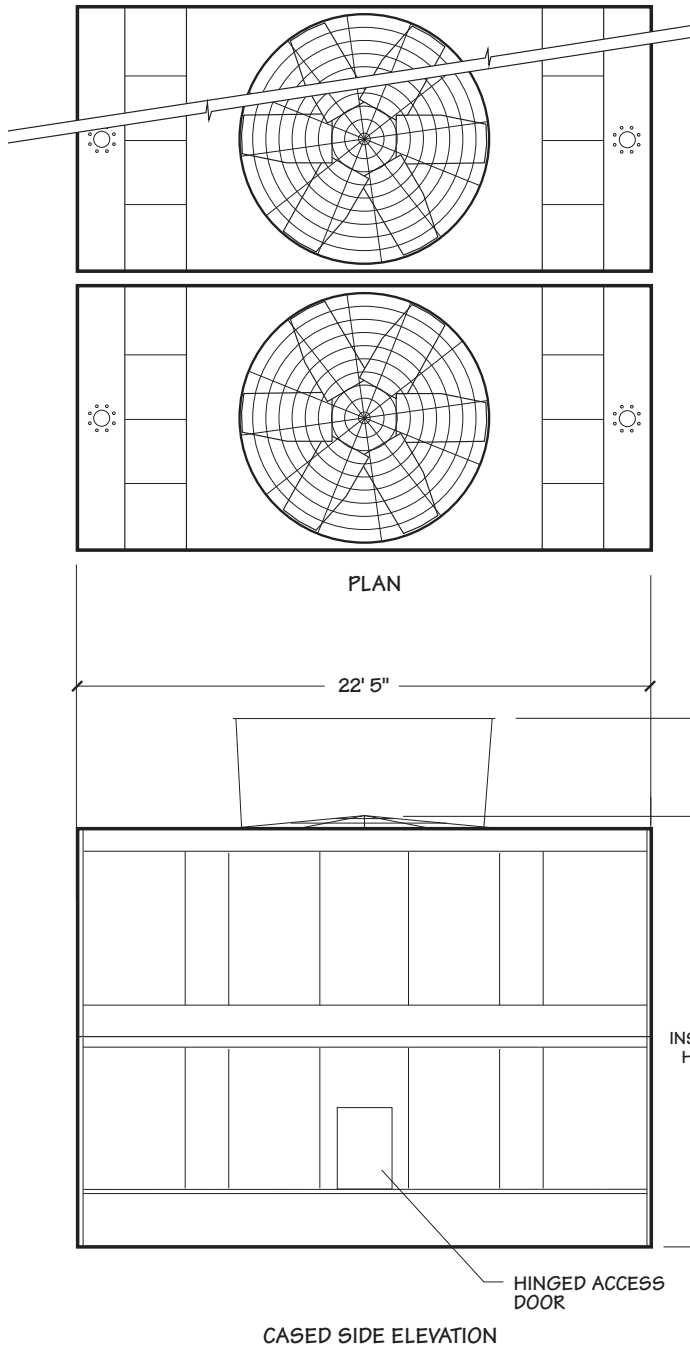

Use this data for preliminary layouts only. Obtain current drawing from your local Marley sales representative.

**UPDATE™** web-based selection software, available at [spxcooling.com/update](http://spxcooling.com/update) provides NC model recommendations based on customer's specific design requirements.

VELOCITY RECOVERY CYLINDER INCREASES MODEL PERFORMANCE. REFER TO DATA TABLE AND UPDATE FOR ADDITIONAL INFORMATION. FAN GUARD NOT REQUIRED.

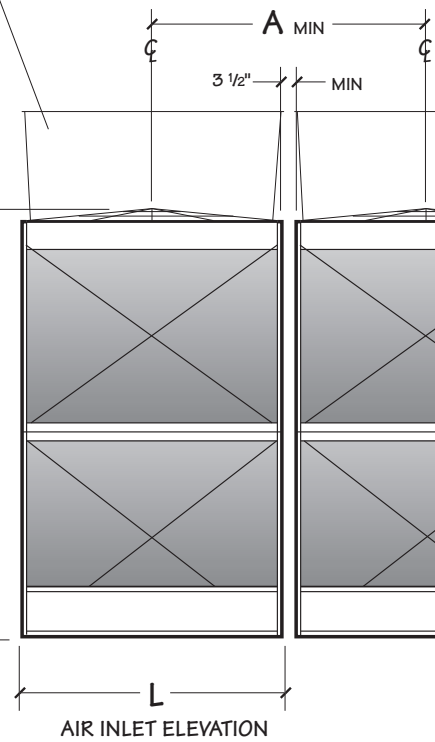



NC8410 NC8411 NC8412

Model note 2	Nominal Tons note 3	Nominal Tons with VR Cylinder note 3	Motor hp	Design Operating Weight lb	Shipping Weight lb	Dimensions			
						L	H	B	A
NC8410N-1	498	522	10	33594	16311	11'-10 <sup>3</sup> / <sub>4</sub> "	16'-0"	20'-6"	12'-2 <sup>1</sup> / <sub>4</sub> "
NC8410P-1	566	593	15						
NC8410Q-1	620	654	20						
NC8410R-1	667	701	25						
NC8410S-1	708	744	30						
NC8410T-1	773	812	40						
NC8410U-1	828	872	50						
NC8410V-1	873	922	60						
NC8410W-1	927	966	75						
NC8411N-1	546	575	10	37334	17608	11'-10 <sup>3</sup> / <sub>4</sub> "	18'-10"	23'-4"	12'-2 <sup>1</sup> / <sub>4</sub> "
NC8411P-1	615	651	15						
NC8411Q-1	672	710	20						
NC8411R-1	717	761	25						
NC8411S-1	756	797	30						
NC8411T-1	822	864	40						
NC8411U-1	875	920	50						
NC8411V-1	920	973	60						
NC8411W-1	975	1032	75						
NC8412P-1	693	730	15	42915	19757	13'-10 <sup>3</sup> / <sub>4</sub> "	18'-10"	23'-4"	14'-2 <sup>1</sup> / <sub>4</sub> "
NC8412Q-1	757	793	20						
NC8412R-1	807	847	25						
NC8412S-1	852	893	30						
NC8412T-1	926	971	40						
NC8412U-1	988	1032	50						
NC8412V-1	1038	1085	60						
NC8412W-1	1107	1156	75						
NC8412X-1	1185	1240	100						

**NOTE**

- 1 Use this bulletin for preliminary layouts only. Obtain current drawings from your Marley sales representative. All table data is per cell.
- 2 Last numeral of model number indicates number of cells. Change as appropriate for your selection.
- 3 Nominal tons are based upon 95°F HW, 85°F CW, 78°F WB, 3 gpm/ton and standard low sound fans. The UPDATE web-based selection software provides NC model recommendations based on specific design requirements.
- 4 Standard overflow is a 4" dia. standpipe in the collection basin floor. The standpipe removes for flush-out and draining. See page 20 for side overflow option.
- 5 Outlet sizes vary according to gpm and arrangement. See pages 20 and 21 for outlet sizes and details.
- 6 Makeup water connection may be 1" or 2" dia., depending upon tower heat load, water pressure, and desired connections. See page 15 for additional information.

NC8413 NC8414

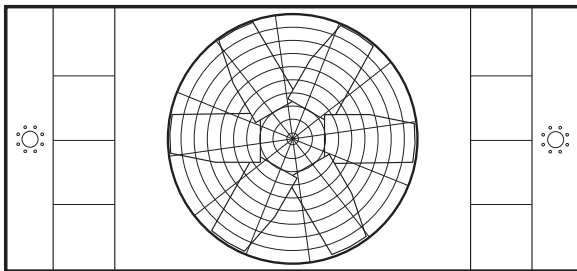
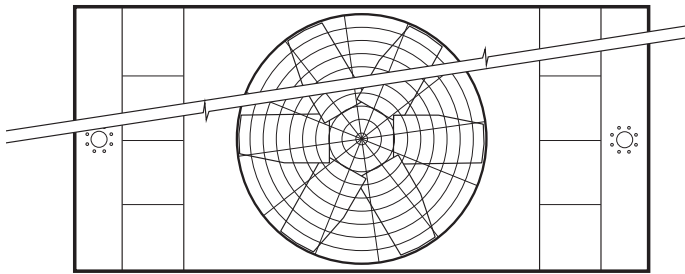

PLAN

22' 5"

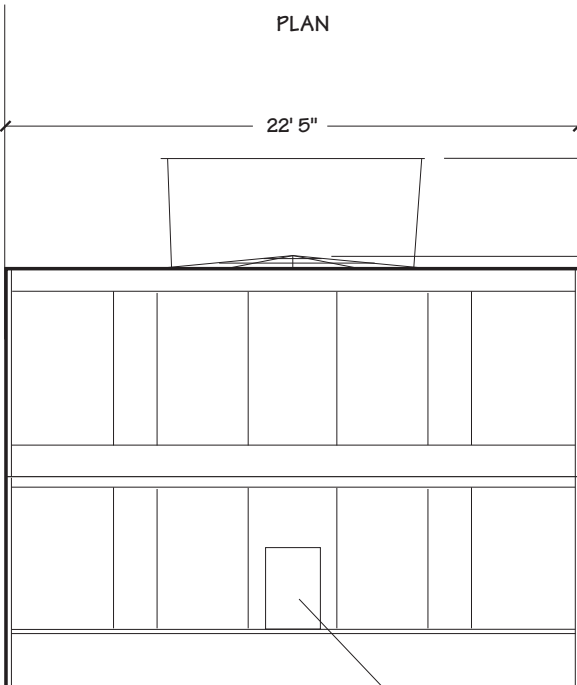

HINGED ACCESS DOOR

CASED SIDE ELEVATION

27'-1 3/16"  
INSTALLED HEIGHT

22'-7 3/16"  
INSTALLED HEIGHT

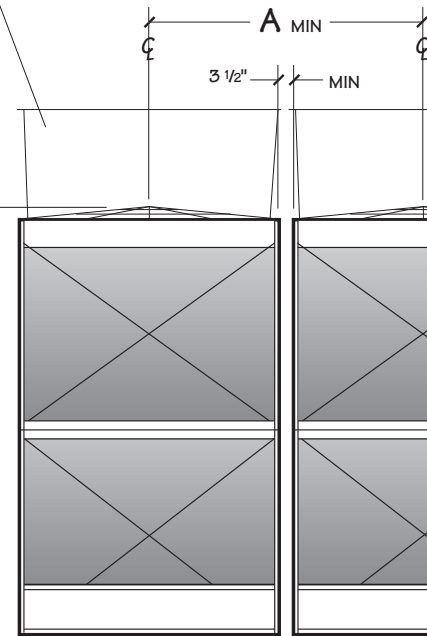

L  
AIR INLET ELEVATION

Use this data for preliminary layouts only. Obtain current drawing from your local Marley sales representative.

**UPDATE™** web-based selection software, available at [spxcooling.com/update](http://spxcooling.com/update) provides NC model recommendations based on customer's specific design requirements.

VELOCITY RECOVERY CYLINDER INCREASES MODEL PERFORMANCE. REFER TO DATA TABLE AND UPDATE FOR ADDITIONAL INFORMATION. FAN GUARD NOT REQUIRED.

NC8413 NC8414

Model note 2	Nominal Tons note 3	Nominal Tons with VR Cylinder note 3	Motor hp	Design Operating Weight lb	Shipping Weight lb	Dimensions	
						L	A
NC8413N-1	598	640	10	41955	19586	11'-10 <sup>3</sup> / <sub>4</sub> "	12'-2 <sup>1</sup> / <sub>4</sub> "
NC8413P-1	674	728	15				
NC8413Q-1	732	781	20				
NC8413R-1	782	835	25				
NC8413S-1	823	878	30				
NC8413T-1	893	957	40				
NC8413U-1	951	1013	50				
NC8413V-1	1001	1065	60				
NC8413W-1	1063	1130	75				
NC8413X-1	1144	1214	100				
NC8414P-1	761	806	15	48355	22096	13'-10 <sup>3</sup> / <sub>4</sub> "	14'-2 <sup>1</sup> / <sub>4</sub> "
NC8414Q-1	827	876	20				
NC8414R-1	883	933	25				
NC8414S-1	927	980	30				
NC8414T-1	1009	1066	40				
NC8414U-1	1074	1133	50				
NC8414V-1	1126	1185	60				
NC8414W-1	1201	1264	75				
NC8414X-1	1288	1358	100				
NC8414Y-1	1370	1455	125				

**NOTE**

- 1 Use this bulletin for preliminary layouts only. Obtain current drawings from your Marley sales representative. All table data is per cell.
- 2 Last numeral of model number indicates number of cells. Change as appropriate for your selection.
- 3 Nominal tons are based upon 95°F HW, 85°F CW, 78°F WB, 3 gpm/ton and standard low sound fans. The UPDATE web-based selection software provides NC model recommendations based on specific design requirements.
- 4 Standard overflow is a 4" dia. standpipe in the collection basin floor. The standpipe removes for flush-out and draining. See page 20 for side overflow option.
- 5 Outlet sizes vary according to gpm and arrangement. See pages 20 and 21 for outlet sizes and details.
- 6 Makeup water connection may be 1" or 2" dia., depending upon tower heat load, water pressure, and desired connections. See page 15 for additional information.

NC8422

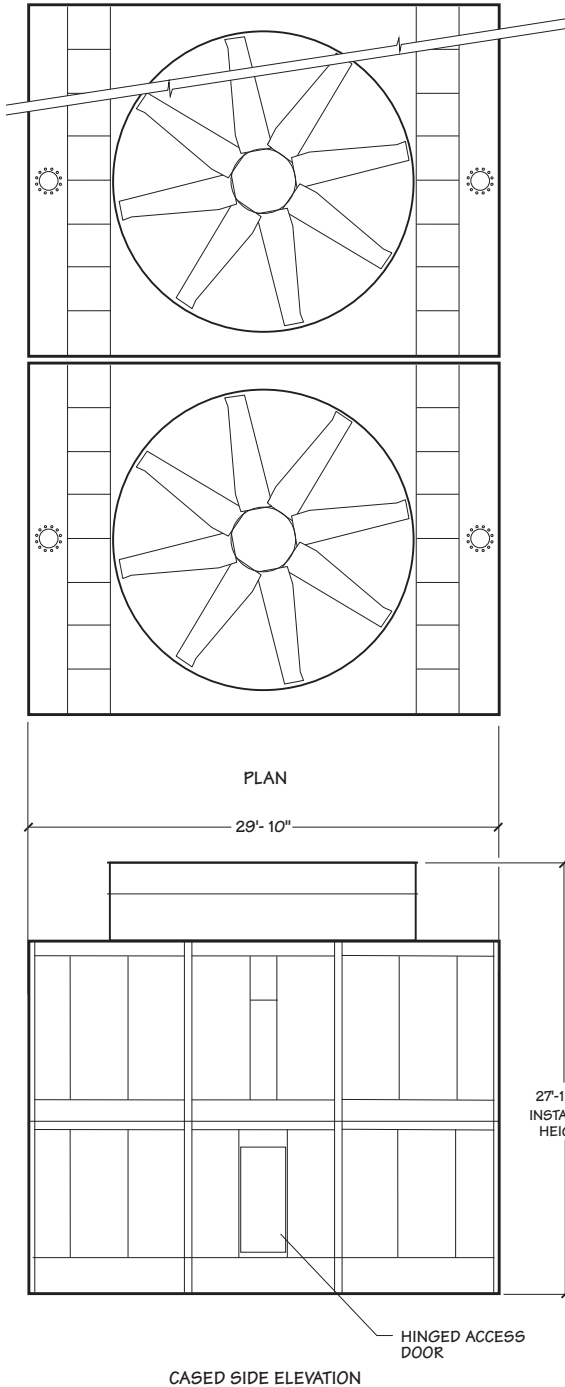

Use this data for preliminary layouts only. Obtain current drawing from your local Marley sales representative.

**UPDATE™** web-based selection software, available at [spxcooling.com/update](http://spxcooling.com/update) provides NC model recommendations based on customer's specific design requirements.

Model note 2	Nominal Tons note 3	Motor hp	Design Operating Weight lb	Shipping Weight lb
NC8422R-1	1311	25	100982	41460
NC8422S-1	1383	30		
NC8422T-1	1490	40		
NC8422U-1	1595	50		
NC8422V-1	1688	60		
NC8422W-1	1810	75		
NC8422X-1	1967	100		
NC8422Y-1	2080	125		
NC8422Z-1	2189	150		

NOTE

- 1 Use this bulletin for preliminary layouts only. Obtain current drawings from your Marley sales representative. All table data is per cell.
- 2 Last numeral of model number indicates number of cells. Change as appropriate for your selection.
- 3 Nominal tons are based upon 95°F HW, 85°F CW, 78°F WB, 3 gpm/ton and standard low sound fans. The UPDATE web-based selection software provides NC model recommendations based on specific design requirements.
- 4 Standard overflow is a 4" dia. standpipe in the collection basin floor. The standpipe removes for flush-out and draining.
- 5 Outlet sizes vary according to gpm and arrangement. See pages 23 for outlet sizes and details.
- 6 Makeup water connection may be 1" or 2" dia., depending upon tower heat load, water pressure, and desired connections. See page 15 for additional information.

When the ambient air temperature falls below 32°F, the water in a cooling tower can freeze. *Marley Technical Report #H-003 “Cooling Towers and Freezing Weather”* describes how to prevent freezing during operation. Available at [spxcooling.com](http://spxcooling.com) or ask your Marley sales representative for a copy.

During shutdown, water collects in the cold water basin and may freeze solid. You can prevent freezing by adding heat to the water left in the tower—or, you can drain the tower and all exposed pipework at shutdown.

### ELECTRIC BASIN HEATERS

An automatic basin water heater system is available consisting of the following components:

- Stainless steel electric immersion heater(s).
  - Threaded couplings are provided in the side of the collection basin.
- NEMA 4 enclosure containing:
  - Magnetic contactor to energize heater.
  - Transformer to convert power supply to 24 volts for control circuit.
  - Solid state circuit board for temperature and low-water cutoff.Enclosure may be mounted on the side of the tower.
- Control probe in the collection basin to monitor water temperature and level.

Heater components are normally shipped separately for installation by others.

**Note:** any exposed piping that is still filled with water at shutdown—including the makeup water line—should be electrically traced and insulated (by others).

### STEAM JET BASIN HEATERS

Penberthy Houdaille bronze steam jet heaters (¼" to ¾") are available for freeze protection (installation by others). Injectors install in a coupling provided in the side of the collection basin. Live steam, as required, is injected directly into the water. Condensed steam adds water to the basin, and the excess will exit the overflow of the tower.

### INDOOR STORAGE TANK

With this type of system, water flows from an indoor tank, through the load system, and back to the tower, where it is cooled. The cooled water flows by gravity from the tower to the tank located in a heated space. At shutdown, all exposed water drains into the tank, where it is safe from freezing. Although we do not produce tanks, many of our representatives offer tanks supplied by reputable manufacturers.

The amount of water needed to successfully operate the system depends on the tower size and gpm and on the volume of water contained in the piping system to and from the tower. You must select a tank large enough to contain those combined volumes—plus a level sufficient to maintain a flooded suction on your pump. Control makeup water according to the level where the tank stabilizes during operation.

Tired of having to design your piping and tower layout to accommodate the standards of cooling tower manufacturers? Marley's multiple variety of piping systems accommodates your design intentions to make your layout of the NC both expedient and economical.

- Single or dual hot water inlet connections.
- Side inlet, bottom inlet or top inlet connections.
- Side cold water outlet connections. NC8401-NC8414.
- Bottom cold water outlet connections.
- A variety of makeup, overflow and drain options.

For the single inlet connection all piping to the distribution basins is part of the tower package. Installation and design costs are reduced and the need for extra piping and supports are eliminated. The single bottom inlet connection is perfect for multicell applications—keeping all the inlet piping below the tower.

Unless otherwise specified, single-cell towers – NC8401 through NC8414 – normally have a cased-face outlet appropriate for the design water flow rate—see pages 20 and 21. This usually assures the lowest possible installed tower elevation. Cased-face outlet connection pipes extend approximately 3" outside the basin, and are beveled for weld connection and also grooved for a mechanical coupling.

Outlet piping can be kept below the cold water basin level by choosing either a depressed sump or a bottom outlet connection in lieu of the cased-face outlets. Both outlet designs conform to standard class 125 ANSI pipe flange specifications. Easily removable debris screens are optional on bottom outlets and are standard on all other outlet arrangements.

Depressed sumps are made of inert fire-retardant FRP or heavy-gauge welded stainless steel. Unless otherwise specified towers with galvanized steel collection basins are supplied with FRP sumps and towers with stainless steel basins are supplied with stainless sumps.

Multicell towers, intended to operate together as a common unit, are joined by steel flumes between the collection basins or piping below the tower basins. These connectors equalize the operating water level between basins and also provide a flow passage from cells not equipped with outlets or makeup valves, often eliminating the need to specify an outlet and makeup valve for each cell on a multicell installation.

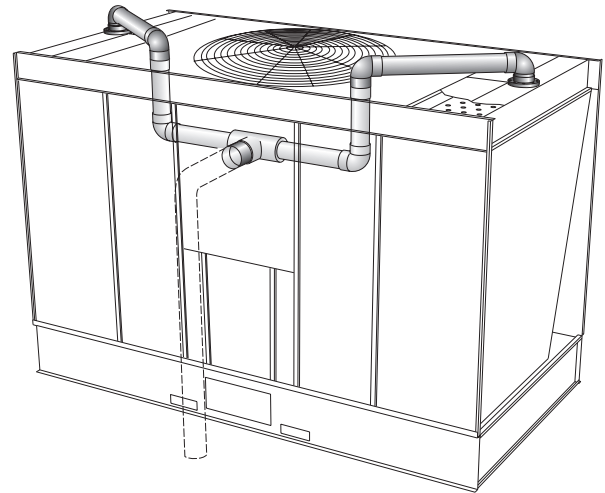

**SIDE INLET PIPING**

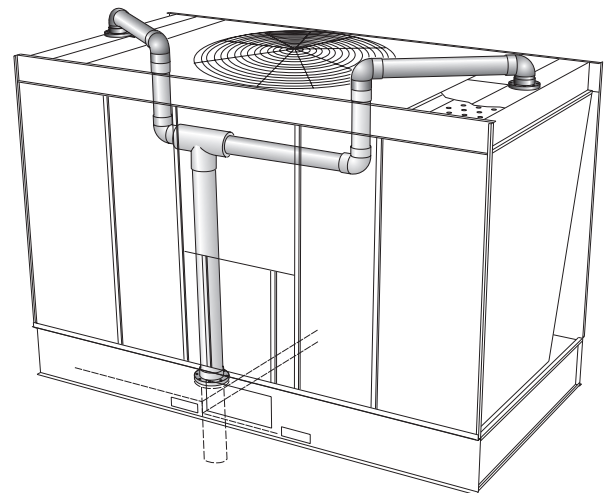

**BOTTOM INLET PIPING**

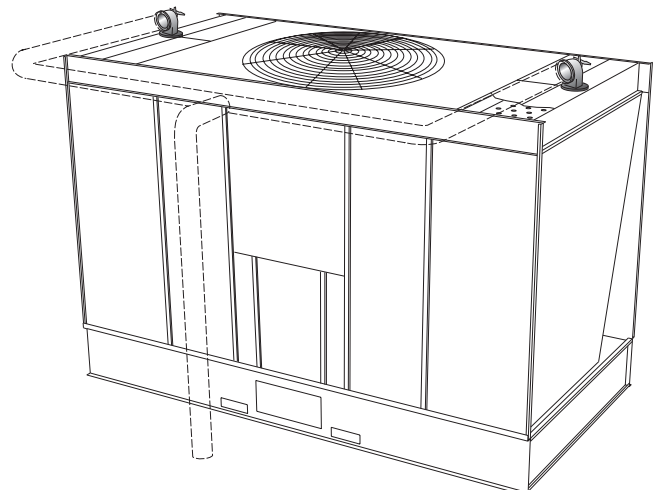

**DUAL TOP INLET PIPING**

If each cell is to be equipped with an outlet, cased-face outlet – NC8401 through NC8414 – can be used on end cells of multicell towers, but not on interior cells. For direct outlet from each cell on installations of three or more cells, use either the depressed sump or bottom outlet on interior cells.

The best choice for a tower used with a remote or indoor storage tank—see page 13—or on a concrete cold water basin is usually a bottom outlet.

A cased-face outlet equipped tower – NC8401 through NC8414 – can be installed on a flat concrete slab if a side drain and overflow are also specified—see page 20. Consult your Marley sales representative for complete information.

**MAKEUP**

The amount of water constantly evaporated from a cooling tower varies directly with the heat load applied. In addition to evaporation, water is normally lost to the blowdown (bleed-off) necessary to maintain dissolved solids concentration at an acceptable level in the circulating water system.

The NC is equipped with one or more float-operated, mechanical makeup valves to automatically replenish this lost water. The tables on this page, calculated for a concentration of 3 times normal, indicate the rate of water loss—and the size of valve(s) required. If your installation’s cold water basin will drain by gravity to a remote storage tank—or if you plan a separate means of controlling makeup water—a price reduction is available for deleting the Marley valve(s). We also offer an optional electronic liquid-level control.

In most instances cooling towers will see the highest water usage at design heat load. Off design conditions (99% of the time) water usage will be less. For a better understanding of how much water your application will use throughout the year, consult our water usage calculator at:

[spxcooling.com/watercalc](http://spxcooling.com/watercalc)

If too much water is still being consumed consult your Marley sales representative for water saving alternatives.

Makeup Water Flow Required—gpm to Maintain Three (3) Concentrations						
Tower gpm	Cooling “Range” (HW – CW)					
	5°F	10°F	15°F	20°F	30°F	40°F
200	2	3	4	5	8	10
400	3	5	8	10	15	20
600	4	8	12	15	23	30
800	5	10	15	20	30	40
1000	7	13	19	25	38	50
1500	10	19	29	38	57	75
2000	13	25	38	50	75	100
3000	19	38	57	75	113	150
4000	25	50	75	100	150	200
5000	32	63	94	125	188	250
6000	38	75	113	150	225	300
8000	50	100	150	200	300	400

**NOTE**

- If circulating water is to be maintained at 2 concentrations instead of 3, multiply table gpm values by 1.36 before sizing makeup valve.

Makeup Valve Flow Capacities—gpm		
Pressure at Valve Inlet while flowing—psig	1" Diameter Valve	2" Diameter Valve
10	56	90
20	78	120
30	92	143
40	106	160
50	117	167

**NOTE**

- If makeup water pressure exceeds 50 psig, use pressure reducer ahead of valve.
- For flow requirements exceeding the above limitations, use multiples of the same size valve.

NC8401 - NC8409

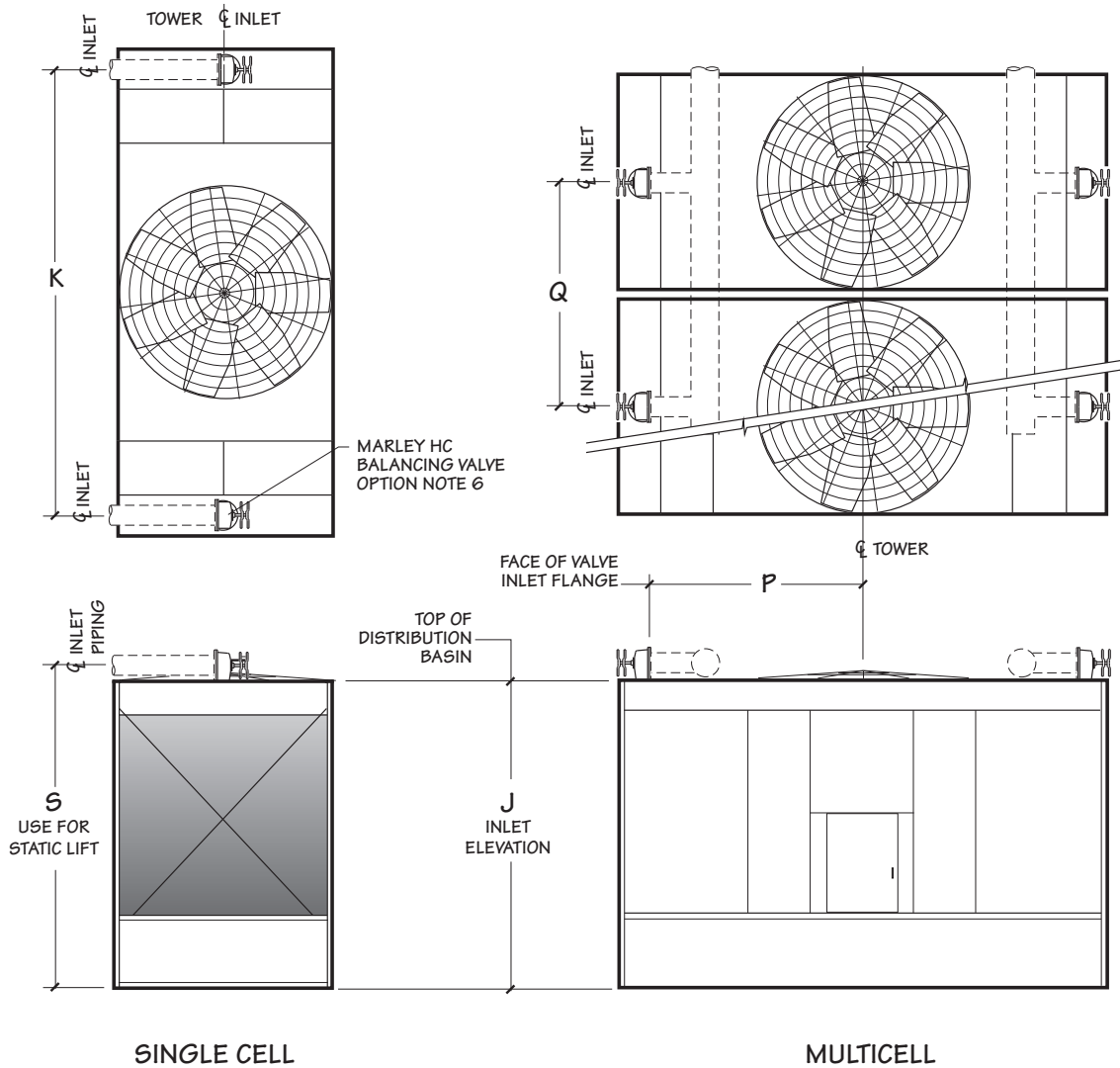

Model	Dimensions					Fan Diameter	Inlet Diameter
	J	K	S	P	Q		
NC8401	9'-9"	11'-1"	10'-5 <sup>3</sup> / <sub>16</sub> "	5'-3"	6'-9 <sup>3</sup> / <sub>4</sub> "	72"	2 at 6"
NC8402	9'-9"	12'-5"	10'-5 <sup>3</sup> / <sub>16</sub> "	5'-11"	8'-8 <sup>1</sup> / <sub>4</sub> "	84"	2 at 6"
NC8403	11'-5 <sup>5</sup> / <sub>16</sub> "	16'-0 <sup>1</sup> / <sub>2</sub> "	12'-2 <sup>7</sup> / <sub>16</sub> "	7'-8 <sup>3</sup> / <sub>4</sub> "	8'-8 <sup>1</sup> / <sub>4</sub> "	84"	2 at 8"
NC8405	11'-5 <sup>5</sup> / <sub>16</sub> "	17'-9 <sup>1</sup> / <sub>2</sub> "	12'-2 <sup>7</sup> / <sub>16</sub> "	8'-7 <sup>1</sup> / <sub>4</sub> "	10'-2 <sup>1</sup> / <sub>4</sub> "	108"	2 at 8"
NC8407	11'-5 <sup>5</sup> / <sub>16</sub> "	19'-0 <sup>7</sup> / <sub>8</sub> "	12'-2 <sup>7</sup> / <sub>16</sub> "	9'-2 <sup>5</sup> / <sub>16</sub> "	12'-2 <sup>1</sup> / <sub>4</sub> "	120"	2 at 8"
NC8409	11'-5 <sup>5</sup> / <sub>16</sub> "	20'-3 <sup>1</sup> / <sub>2</sub> "	12'-4 <sup>7</sup> / <sub>16</sub> "	9'-9 <sup>1</sup> / <sub>2</sub> "	14'-2 <sup>1</sup> / <sub>4</sub> "	144"	2 at 10"



NC8410 - NC8422

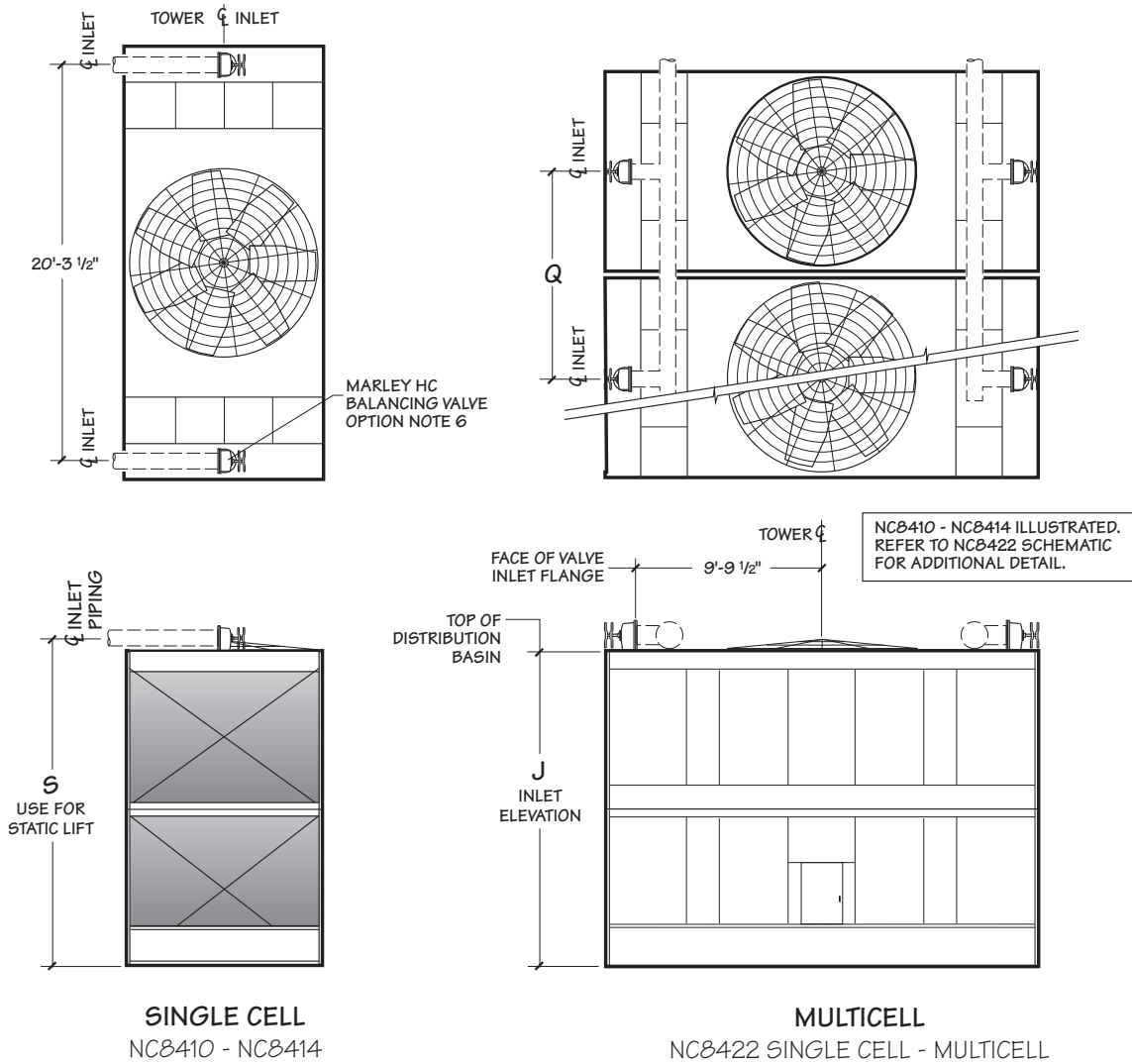

Model	Dimensions			Fan Diameter	Inlet Diameter
	J	S	Q		
NC8410	15'-6"	16'-5"	12'-2 1/4"	132"	2 at 10"
NC8411	18'-3 5/8"	19'-2 3/4"	12'-2 1/4"	132"	2 at 10"
NC8412	18'-3 5/8"	19'-2 1/4"	14'-2 1/4"	144"	2 at 10"
NC8413	22'-0 3/4"	22'-11 3/8"	12'-2 1/4"	132"	2 at 10"
NC8414	22'-0 3/4"	22'-11 3/8"	14'-2 1/4"	144"	2 at 10"
NC8422	22'-0 3/4"	23'-1 7/8"	22'-8 1/2"	228"	2 at 14"

NOTE

- 1 Use this bulletin for preliminary layouts only. Obtain current drawings from your Marley sales representative.
- 2 Pumping head contributed by the tower is static lift "S". Add your system dynamic pipe losses for total.
- 3 The tower will support the vertical weight of piping shown within the plan area of the tower only. All piping loads, including thrust and lateral loads of riser and horizontal piping must be supported independent of the tower. See inlet piping drawings for details.
- 4 All piping and supports—and their design—are by others.
- 5 Allow adequate clearance for entry to tower access doors and safe use of optional ladder. Refer to appropriate Marley drawings.
- 6 You may choose to use 90° short radius flanged elbows in place of HC balancing valves on single-cell towers where inlet piping is balanced for equal flow. Pipe elevation remains as shown.

NC8401 - NC8409

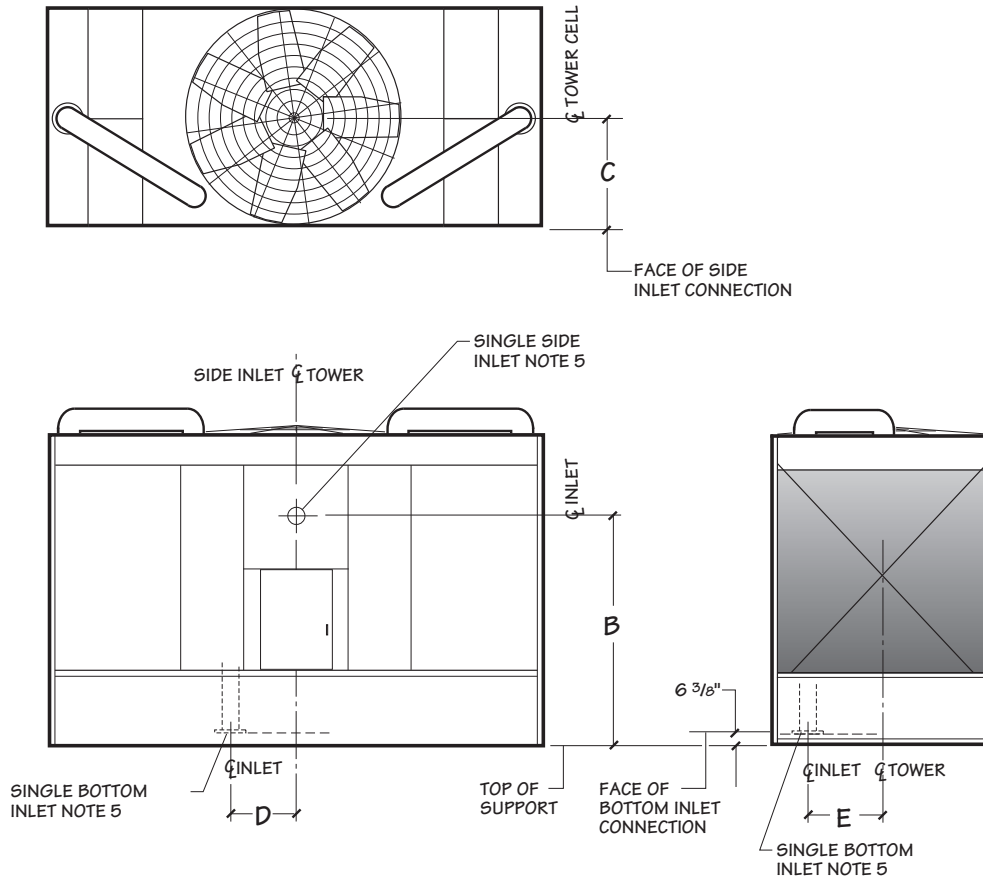

Model	Dimensions				Inlet Diameter
	B	C	D	E	
NC8401	7'-6 <sup>7</sup> / <sub>16</sub> "	3'-3 <sup>1</sup> / <sub>16</sub> "	na	na	6"
NC8402	7'-6 <sup>5</sup> / <sub>8</sub> "	5'-0 <sup>13</sup> / <sub>16</sub> "	2'-4 <sup>1</sup> / <sub>8</sub> "	2'-0"	8"
NC8403	9'-3 <sup>9</sup> / <sub>16</sub> "	5'-0 <sup>11</sup> / <sub>16</sub> "	2'-4 <sup>3</sup> / <sub>16</sub> "	2'-5"	8"
NC8405	9'-2 <sup>9</sup> / <sub>16</sub> "	5'-11 <sup>7</sup> / <sub>8</sub> "	2'-7 <sup>11</sup> / <sub>16</sub> "	3'-0 <sup>1</sup> / <sub>4</sub> "	10"
NC8407	9'-1 <sup>11</sup> / <sub>16</sub> "	7'-0 <sup>1</sup> / <sub>16</sub> "	2'-10 <sup>5</sup> / <sub>8</sub> "	4'-2"	10"
NC8409	9'-2 <sup>1</sup> / <sub>8</sub> "	8'-0"	2'-10 <sup>7</sup> / <sub>8</sub> "	4'-8"	10"

NOTE

- 1 Use this bulletin for preliminary layouts only. Obtain current drawings from your Marley sales representative.
- 2 All external piping loads, including weight, thrust and lateral loads of riser and horizontal piping plus the weight of water in the internal riser must be supported independent of the tower. Internal riser adds additional vertical operating loads to external piping at the bottom inlet flange.
- 3 All piping and supports beyond the inlet connection—and their design—are by others.
- 4 Allow adequate clearance for entry to tower access doors and safe use of optional ladder. Refer to appropriate Marley drawings.
- 5 You may choose either a bottom inlet connection or a side inlet connection. The bottom inlet connects at the tower collection basin floor. Refer to appropriate Marley drawings.
- 6 Contact your Marley sales representative for the required pump head for single-inlet applications.
- 7 Weight of internal piping must be added to tower weights. Contact your Marley sales representative for combined tower weight information.

NC8410 - NC8414

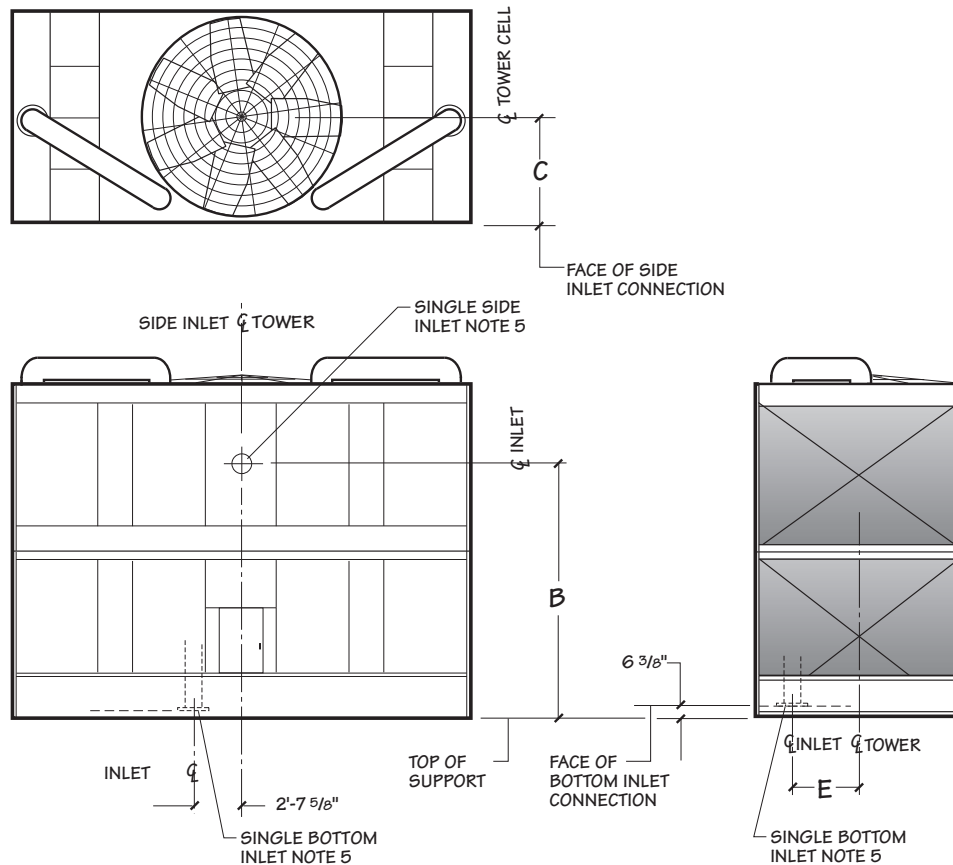

Model	Dimensions			Inlet Diameter
	B	C	E	
NC8410	13'-3 1/2"	7'-3 7/16"	4'-6"	10"
NC8411	16'-1 1/2"	7'-3 7/16"	4'-6"	12"
NC8412	16'-1 1/2"	8'-2 1/2"	5'-5 15/16"	12"
NC8413	19'-10 5/8"	7'-3 7/16"	4'-6"	12"
NC8414	19'-10 5/8"	8'-2 1/2"	5'-5 15/16"	12"

NOTE

- 1 Use this bulletin for preliminary layouts only. Obtain current drawings from your Marley sales representative.
- 2 All external piping loads, including weight, thrust and lateral loads of riser and horizontal piping plus the weight of water in the internal riser must be supported independent of the tower. Internal riser adds additional vertical operating loads to external piping at the bottom inlet flange.
- 3 All piping and supports beyond the inlet connection—and their design—are by others.
- 4 Allow adequate clearance for entry to tower access doors and safe use of optional ladder. Refer to appropriate Marley drawings.
- 5 You may choose either a bottom inlet connection or a side inlet connection. The bottom inlet connects at the tower collection basin floor. Refer to appropriate Marley drawings.
- 6 Contact your Marley sales representative for the required pump head for single-inlet applications.
- 7 Weight of internal piping must be added to tower weights. Contact your Marley sales representative for combined tower weight information.

NC8401 - NC8414

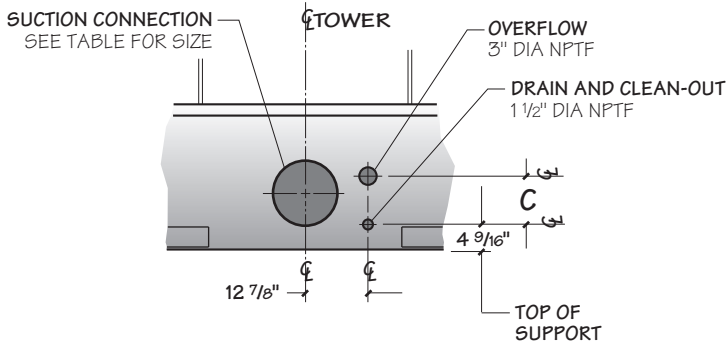

**DRAIN AND OVERFLOW CONNECTION  
OPTION**

Model	Dimensions		
	A	B	C
NC8401	10"	3'-4 1/8"	8 1/8"
NC8402	10"	4'-3 3/8"	8 1/8"
NC8403	11 1/4"	4'-3 3/8"	8 15/16"
NC8405	11 1/4"	5'-0 3/8"	8 15/16"
NC8407	11 1/4"	6'-0 3/8"	8 15/16"
NC8409	11 1/4"	7'-0 3/8"	8 15/16"
NC8410	11 1/4"	6'-0 3/8"	11 1/2"
NC8411	11 1/4"	6'-0 3/8"	13 5/16"
NC8412	11 1/4"	7'-0 3/8"	13 5/16"
NC8413	11 1/4"	6'-0 3/8"	13 5/16"
NC8414	11 1/4"	7'-0 3/8"	13 5/16"

**NOTE**

- Standard overflow is a 4" dia. standpipe in the collection basin floor. The standpipe removes for flush-out and draining.

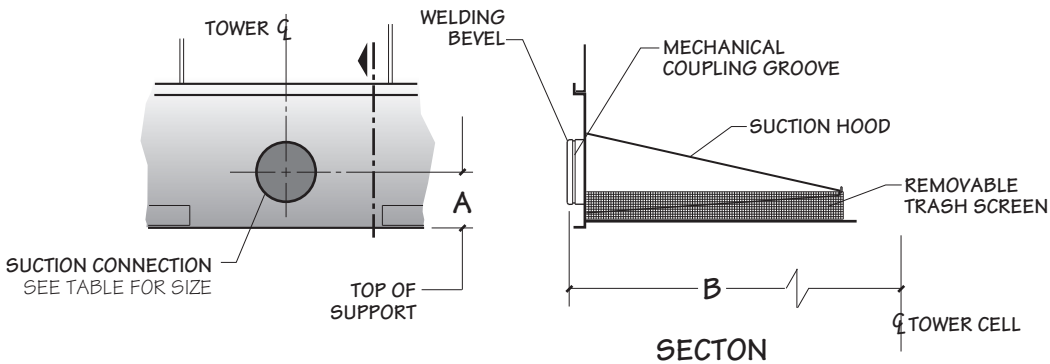

**CASED-FACE OUTLET CONNECTION**

NC8401 - NC8414

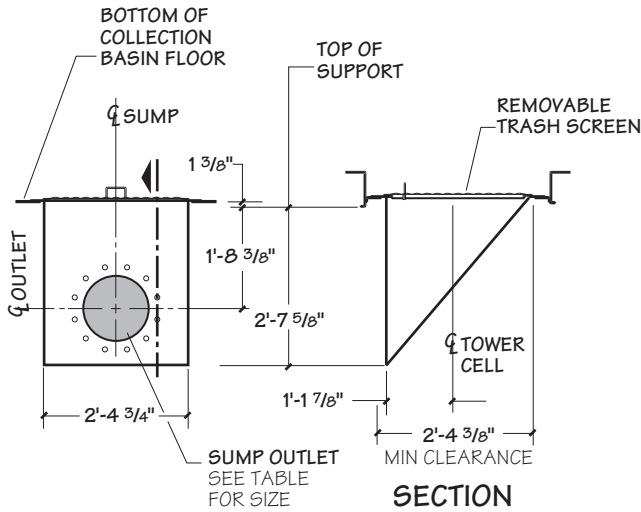

**DEPRESSED SIDE-OUTLET  
SUMP CONNECTION**  
STAINLESS STEEL OR FRP

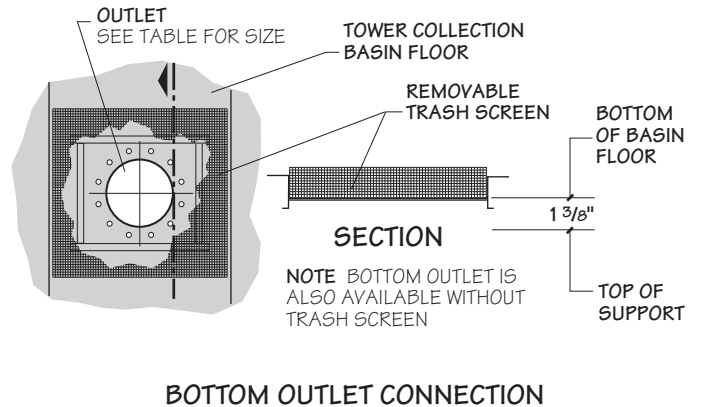

**BOTTOM OUTLET CONNECTION**

Maximum gpm Per Outlet Diameter												
Outlet Type	Flow Type	Model	Outlet Diameter									
			4"	6"	8"	10"	12"	14"	16"	18"	20"	24"
Bottom	pump flow w/ anti-vortex plate or gravity flow w/ or w/o anti-vortex plate	NC8401 thru NC8405	157	355	630	993	1413	1729	2285	2509	3322	4019
		NC8407 thru NC8414	167	380	673	1061	1510	1848	2442	3164	3829	4896
	pump flow w/o anti-vortex plate	NC8401 thru NC8414	71	162	287	453	644	788	1042	1349	1676	2433
Sump	pump flow w/ anti-vortex plate or gravity flow w/ or w/o anti-vortex plate	NC8401 thru NC8405		900	1595	2515	3578	4284				
		NC8407 thru NC8414		900	1595	2515	3578	4379				
	pump flow w/o anti-vortex plate	NC8401 thru NC8414		630	1116	1761	2505	3065				
Cased-Face Outlet	pump flow only	NC8401 thru NC8405		900	1595	2515	3578					
		NC8407 thru NC8414		900	1595	2515	3578	4379				

**NOTE**

- Flow rate may be limited by the maximum gpm for unit size.
- For gravity-flow situations (as to an indoor tank), use bottom outlet or depressed side outlet sump. Cased-face outlet is not recommended for gravity flow.
- gpm limits are the outlet capacities per outlet based on the design operating water level—81/2" above the top of support on models NC8401 through NC8405—91/w2" on NC8407 thru NC8414.

NC8422

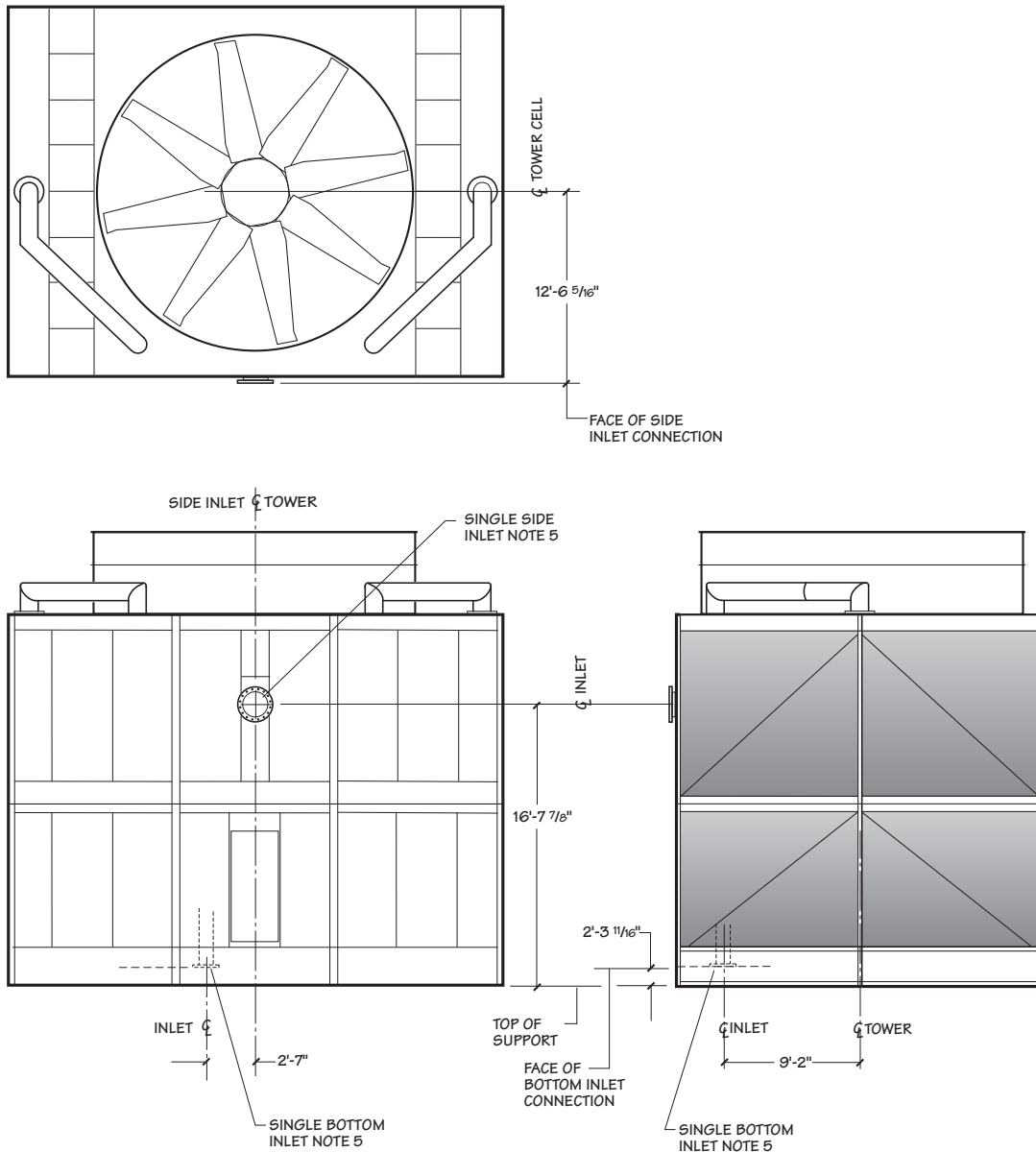

NOTE

- 1 Use this bulletin for preliminary layouts only. Obtain current drawings from your Marley sales representative.
- 2 All external piping loads, including weight, thrust and lateral loads of riser and horizontal piping plus the weight of water in the internal riser must be supported independent of the tower. Internal riser adds additional vertical operating loads to external piping at the bottom inlet flange.
- 3 All piping and supports beyond the inlet connection—and their design—are by others.
- 4 Allow adequate clearance for entry to tower access doors and safe use of optional ladder. Refer to appropriate Marley drawings.
- 5 You may choose either a bottom inlet connection or a side inlet connection. The bottom inlet connects at the tower collection basin floor. Refer to appropriate Marley drawings.
- 6 Contact your Marley sales representative for the required pump head for single-inlet applications.
- 7 Weight of internal piping must be added to tower weights. Contact your Marley sales representative for combined tower weight information.

NC8422

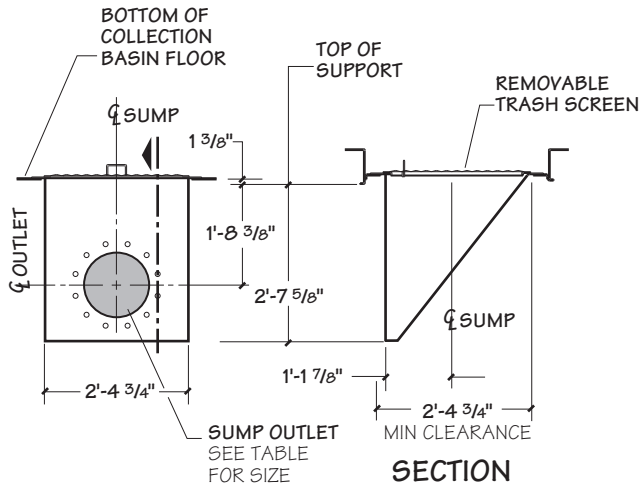

**DEPRESSED SIDE-OUTLET  
SUMP CONNECTION**

STAINLESS STEEL OR FRP UP TO 14" DIAMETER

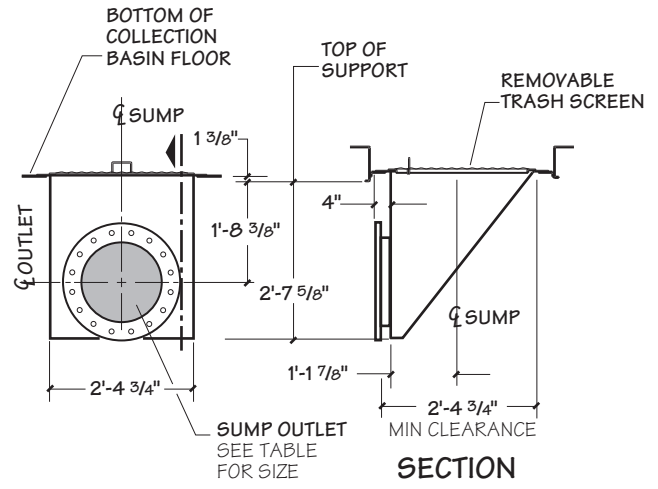

**DEPRESSED SIDE-OUTLET  
FLANGED SUMP CONNECTION**

16" AND 18" DIAMETER

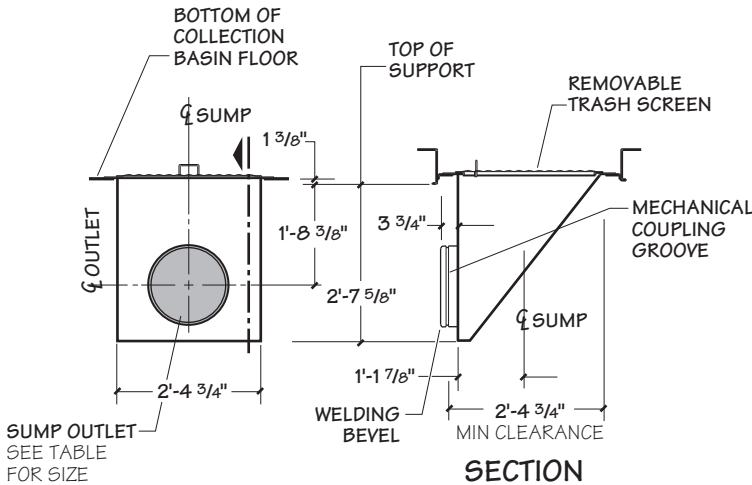

**DEPRESSED SIDE-OUTLET  
BEVEL - GROOVED CONNECTION**

16" AND 18" DIAMETER

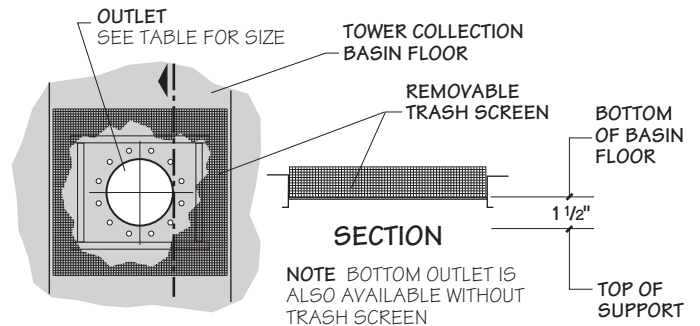

**BOTTOM OUTLET CONNECTION**

		Maximum gpm Per Outlet Diameter								
Outlet Type	Flow Type	Outlet Diameter								
		6"	8"	10"	12"	14"	16"	18"	20"	24"
Bottom	pump flow w/ anti-vortex plate or gravity flow w/ or w/o anti-vortex plate		757	1194	1699	2079	2748	3560	4420	6419
Sump	pump flow with anti-vortex plate	900	1595	2515	3578	4379	5787	7746		

**NOTE**

- Flow rate may be limited by the maximum gpm for unit size.
- 16" and 18" sumps are only available in stainless steel.
- For gravity-flow situations (as to an indoor tank), use bottom outlet.
- Flow limits are the outlet capacities per outlet based on 11 5/8" design operating water level.

NC8401 - NC8414

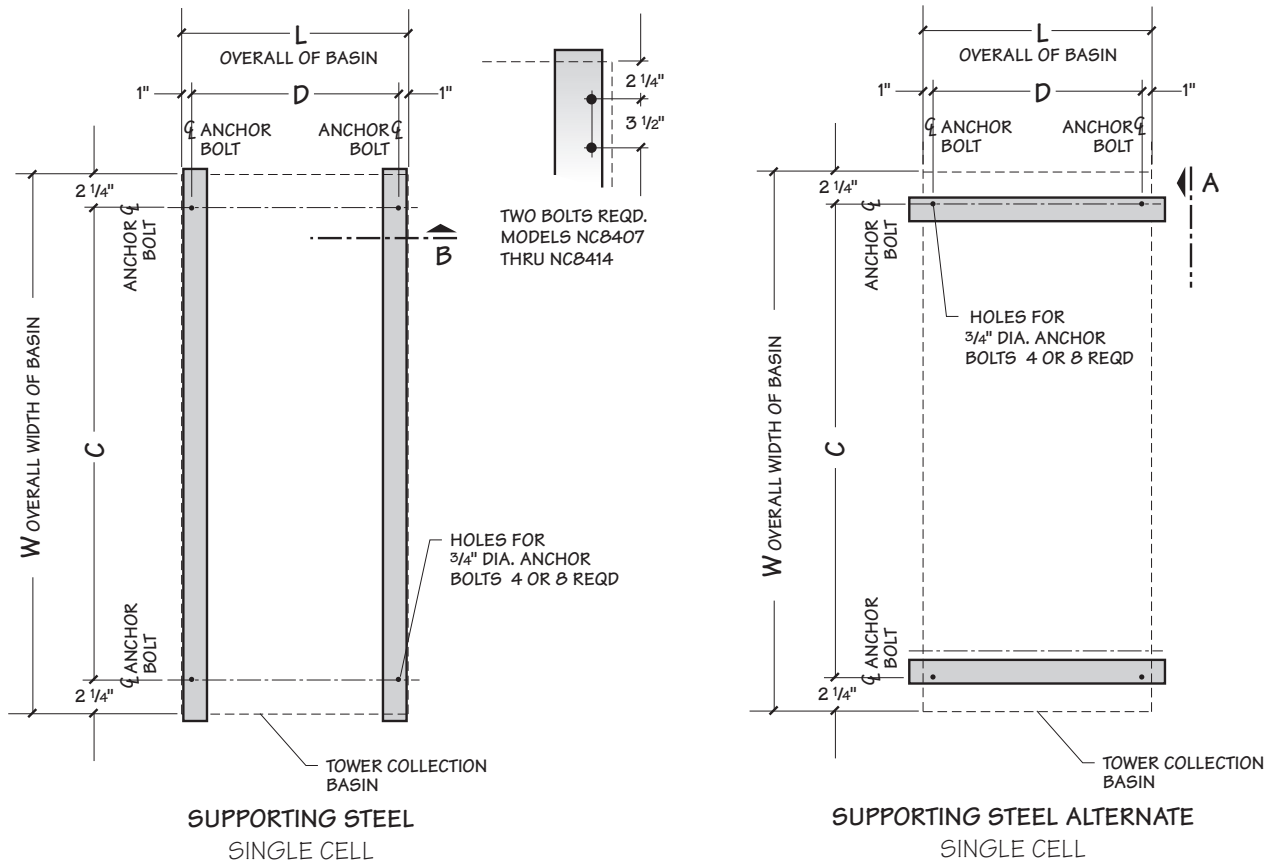

Model	Dimensions				Design Operating Weight/Cell lb	Design Operating Load at Anchor lb
	W	L	C	D		
NC8401	12'-10"	6'-6 1/4"	12'-5 1/2"	6'-4 1/4"	7810	1952
NC8402	14'-2"	8'-4 3/4"	13'-9 1/2"	8'-2 3/4"	10171	2543
NC8403	18'-2"	8'-4 3/4"	17'-9 1/2"	8'-2 3/4"	15812	3953
NC8405	19'-11"	9'-10 3/4"	19'-6 1/2"	9'-8 3/4"	19691	4923
NC8407	21'-0"	11'-10 3/4"	20'-7 1/2"	11'-8 3/4"	24824	6206
NC8409	22'-5"	13'-10 3/4"	22'-0 1/2"	13'-8 3/4"	30013	7503
NC8410	22'-5"	11'-10 3/4"	22'-0 1/2"	11'-8 3/4"	33594	8399
NC8411	22'-5"	11'-10 3/4"	22'-0 1/2"	11'-8 3/4"	37334	9334
NC8412	22'-5"	13'-10 3/4"	22'-0 1/2"	13'-8 3/4"	42915	10729
NC8413	22'-5"	11'-10 3/4"	22'-0 1/2"	11'-8 3/4"	41995	10489
NC8414	22'-5"	13'-10 3/4"	22'-0 1/2"	13'-8 3/4"	48355	12089

NOTE

- 1 Use this bulletin for preliminary layouts only. Obtain current drawings from your Marley sales representative for final design.
- 2 Purchaser to provide tower support complete with holes and anchor bolts. Do not use studs! Anchor points must be framed flush and level at top.
- 3 Design operating weight occurs with collection basin full to overflow level. Actual operating weight varies with gpm and piping scheme.
- 4 Tower may be placed on a flat concrete slab. Side outlet and optional side drain and overflow must be specified. See pages 13 and 18 and consult your Marley sales representative.
- 5 Tower may be supported from piers at each anchor bolt location, as a support alternative.
6. Dimensions between anchor bolts may vary depending on the number of cells and options. Dimensions shown are for a standard two cell arrangement. Obtain current drawings from your Marley sales representative for final dimension.



NC8401 - NC8414

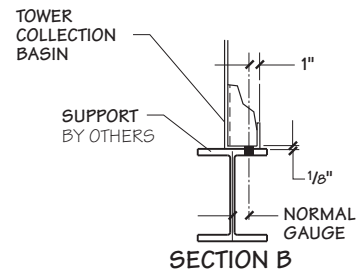
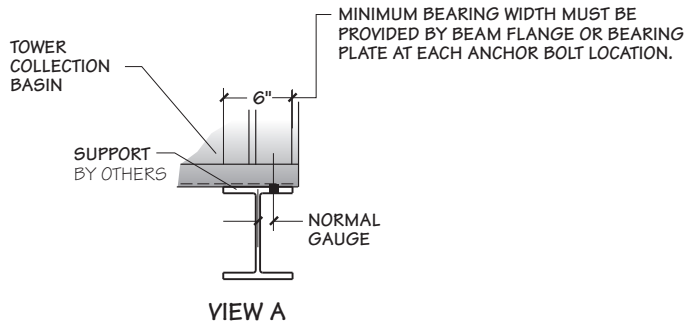
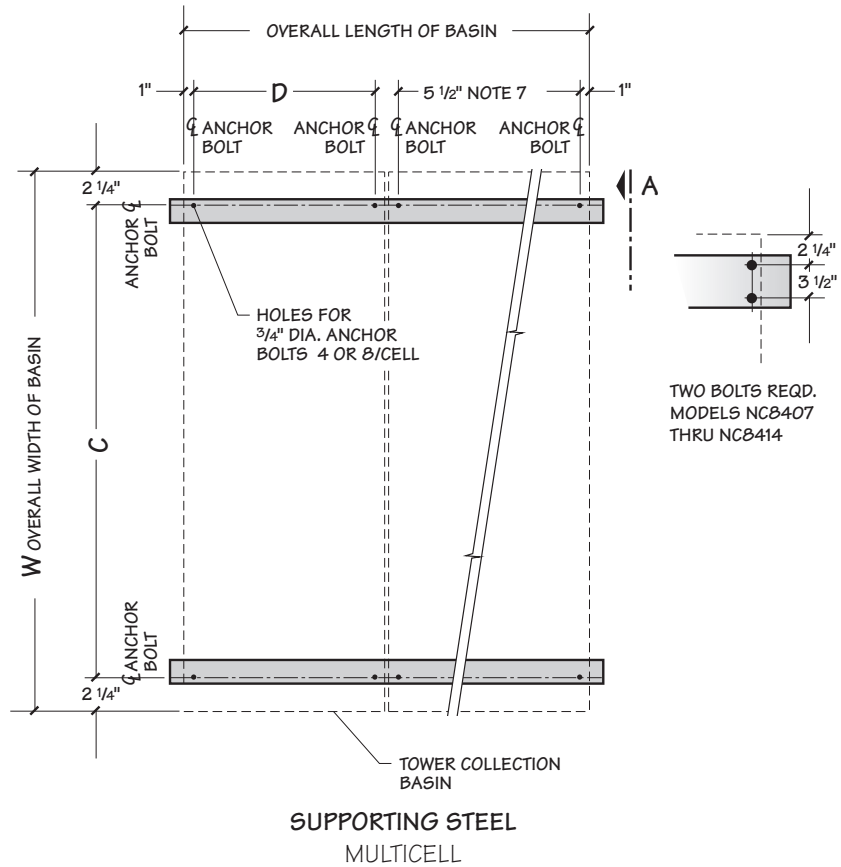

NOTE

- 1 Use this bulletin for preliminary layouts only. Obtain current drawings from your Marley sales representative for final design.
- 2 Purchaser to provide tower support complete with holes and anchor bolts. Do not use studs! Anchor points must be framed flush and level at top.
- 3 Design operating weight occurs with collection basin full to overflow level. Actual operating weight varies with gpm and piping scheme.
- 4 Tower may be placed on a flat concrete slab. Side outlet and optional side drain and overflow must be specified. See pages 13 and 18 and consult your Marley sales representative.
- 5 Tower may be supported from piers at each anchor bolt location, as a support alternative.
6. Dimensions between anchor bolts may vary depending on the number of cells and options. Dimensions shown are for a standard two cell arrangement. Obtain current drawings from your Marley sales representative for final dimension.

NC8422

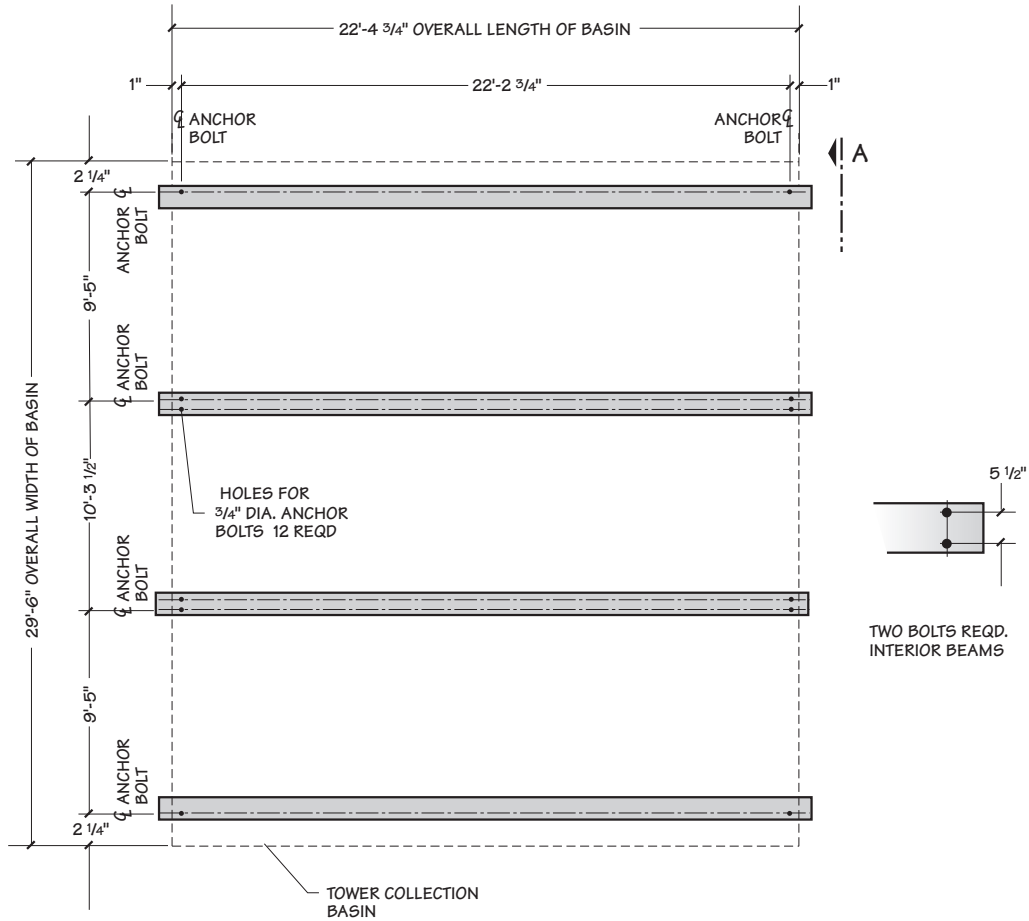

SUPPORTING STEEL  
SINGLE CELL

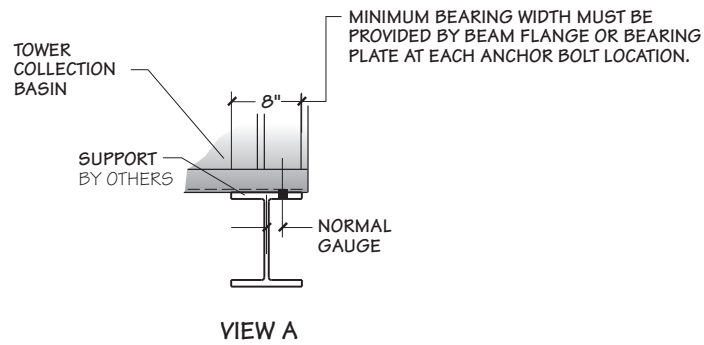

NC8422

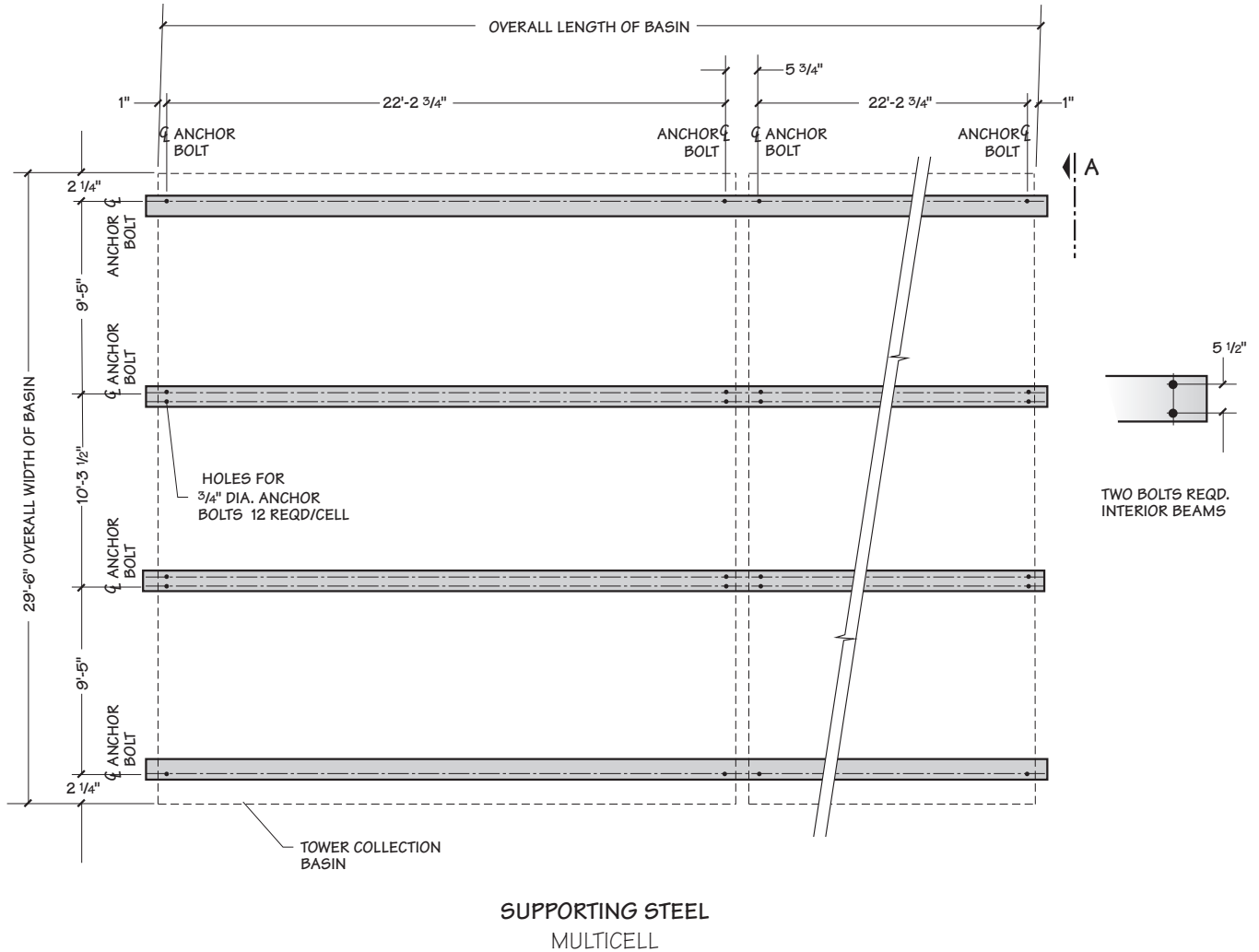

**NOTE**

- 1 Use this bulletin for preliminary layouts only. Obtain current drawings from your Marley sales representative for final design.
- 2 Purchaser to provide tower support complete with holes and anchor bolts. Do not use studs! Anchor points must be framed flush and level at top.
- 3 Design operating weight occurs with collection basin full to overflow level. Actual operating weight varies with gpm and piping scheme.
- 4 Tower may be supported from piers at each anchor bolt location, as a support alternative. Consult your Marley sales representative for additional details.
5. Dimensions between anchor bolts may vary depending on the number of cells and options. Dimensions shown are for a standard two cell arrangement. Obtain current drawings from your Marley sales representative for final dimension.

NC8401 - NC8414

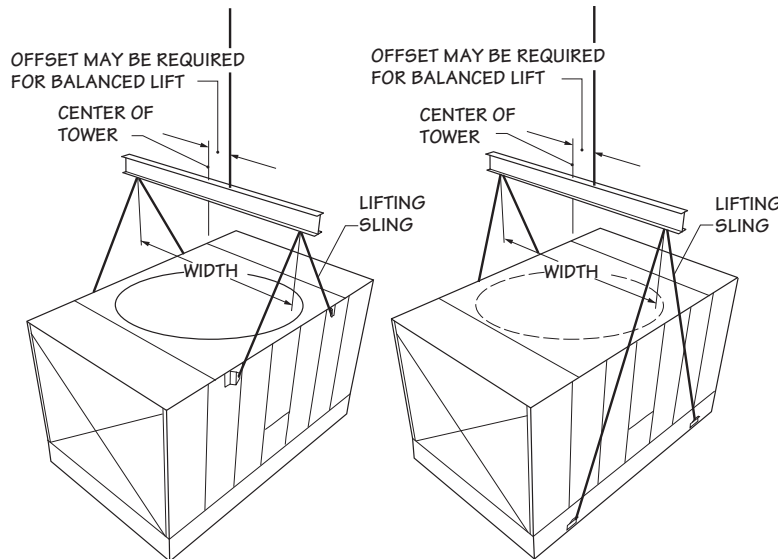

Model	Width	Minimum Sling Length
NC8401	6'-7"	6'-0"
NC8402	8'-6"	6'-0"
NC8403	8'-6"	8'-0"
NC8405	10'-0"	8'-0"
NC8407	12'-0"	9'-0"
NC8409	14'-0"	18'-0"
NC8410 Top	12'-0"	9'-0"
NC8410 Bottom	12'-0"	16'-6"
NC8411 Top	12'-0"	9'-0"
NC8411 Bottom	12'-0"	18'-0"
NC8412 Top	14'-0"	9'-0"
NC8412 Bottom	14'-0"	18'-0"
NC8413 Top	12'-0"	9'-0"
NC8413 Bottom	12'-0"	18'-0"
NC8414 Top	14'-0"	9'-0"
NC8414 Bottom	14'-0"	18'-0"

**NOTE**

- All hoisting clip holes are 1 ¼".
- On multicell tower installations, overall length of shackle pins should not exceed 5 ¼".
- For overhead lifts or where additional safety is required, add slings beneath the tower unit.

NC8422

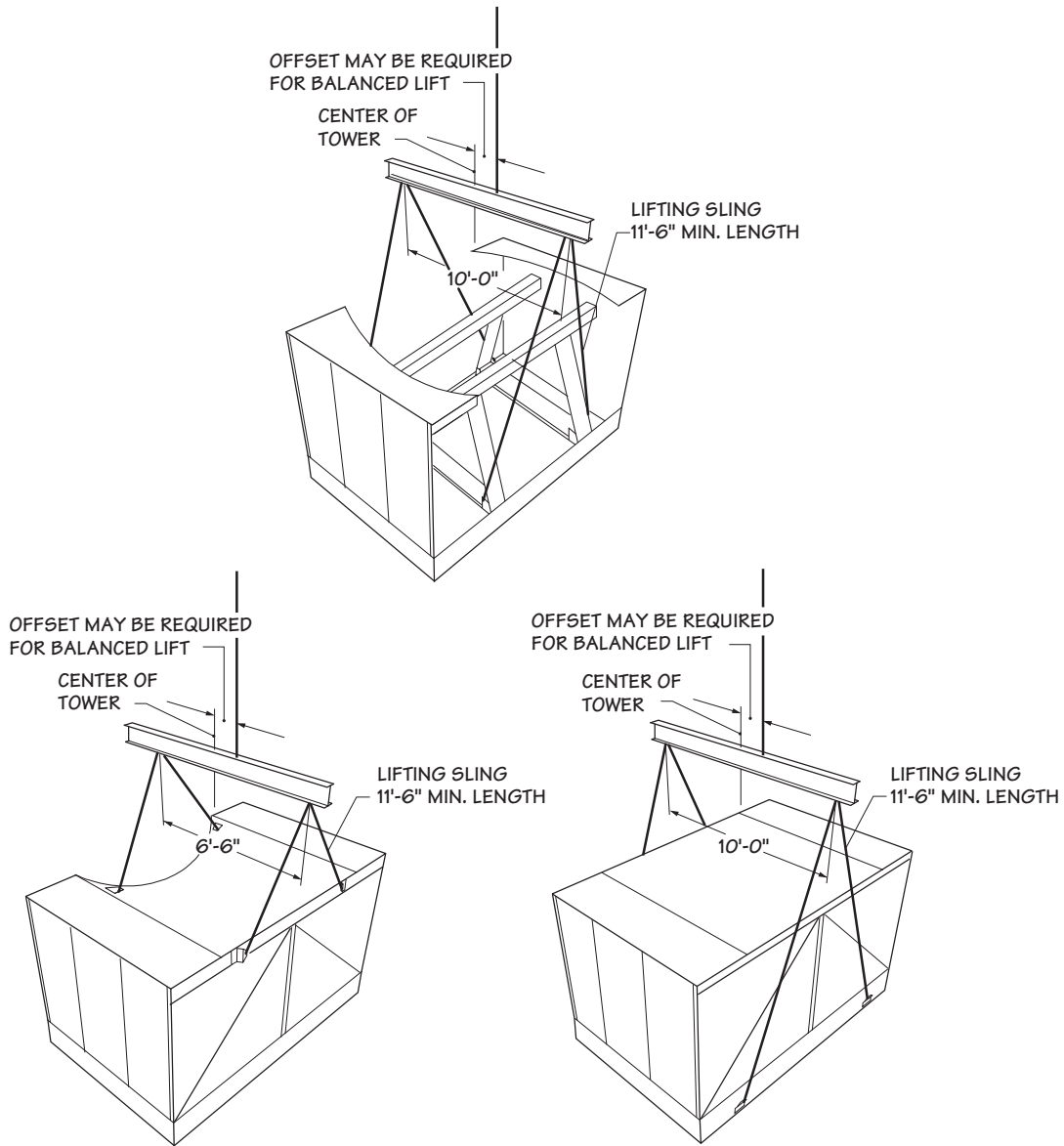

**NOTE**

- All hoisting clip holes are 1¼".
- Overall length of shackle pins should not exceed 2½".
- For overhead lifts or where additional safety is required, add slings beneath the tower unit.

NC8401 - NC8414

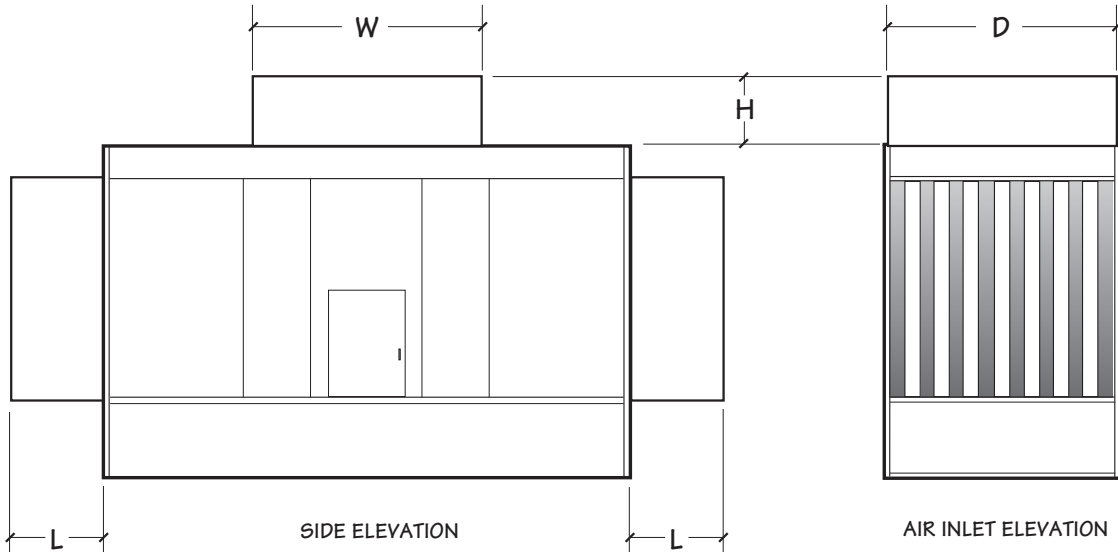

Model	Dimensions				Add To Design Operating Weight lb	
	L	W	D	H	Discharge Attenuator	Inlet Attenuators
NC8401	2'-3 1/4"	6'-10"	6'-1 1/2"	2'-3"	620	1523
	4'-6 1/2"	6'-10"	6'-1 1/2"	4'-6"	1241	3045
NC8402	2'-3 1/4"	7'-10 1/4"	8'-0"	2'-3"	774	1869
	4'-6 1/2"	7'-10 1/4"	8'-0"	4'-6"	1547	3738
NC8403	2'-3 1/4"	7'-10 1/4"	8'-0"	2'-3"	774	2101
	4'-6 1/2"	7'-10 1/4"	8'-0"	4'-6"	1547	4201
NC8405	2'-3 1/4"	9'-9"	9'-6"	2'-3"	1051	2460
	4'-6 1/2"	9'-9"	9'-6"	4'-6"	2102	4920
NC8407	2'-3 1/4"	10'-8 3/8"	11'-6"	2'-3"	1395	3115
	4'-6 1/2"	10'-8 3/8"	11'-6"	4'-6"	2791	6231
NC8409	2'-3 1/4"	12'-9 3/8"	13'-6"	2'-3"	1616	3508
	4'-6 1/2"	12'-9 3/8"	13'-6"	4'-6"	3233	7016
NC8410	2'-3 1/4"	11'-8 7/8"	11'-6"	2'-3"	1564	5042
	4'-6 1/2"	11'-8 7/8"	11'-6"	4'-6"	3128	10083
NC8411	2'-3 1/4"	11'-8 7/8"	11'-6"	2'-3"	1564	5562
	4'-6 1/2"	11'-8 7/8"	11'-6"	4'-6"	3128	11125
NC8412	2'-3 1/4"	12'-9 3/8"	13'-6"	2'-3"	1616	6272
	4'-6 1/2"	12'-9 3/8"	13'-6"	4'-6"	3233	12545
NC8413	2'-3 1/4"	11'-8 7/8"	11'-6"	2'-3"	1564	6417
	4'-6 1/2"	11'-8 7/8"	11'-6"	4'-6"	3128	12834
NC8414	2'-3 1/4"	12'-9 3/8"	13'-6"	2'-3"	1616	7051
	4'-6 1/2"	12'-9 3/8"	13'-6"	4'-6"	3233	14103

NOTE

- 1 Use this bulletin for preliminary layouts only. Obtain current drawings from your Marley sales representative. All table data is per cell.
- 2 Attenuators are field installed by others with hardware provided by Marley
- 3 Attenuators are supported by the tower. Additional support not required.
- 4 Discharge attenuators are not available for NC models with velocity recovery cylinders.
- 5 Attenuators are not available for NC8422 model.





---

**SPX COOLING TECHNOLOGIES, INC.**

7401 WEST 129 STREET  
OVERLAND PARK, KS 66213 USA  
913 664 7400 | [spxcooling@spx.com](mailto:spxcooling@spx.com)  
[spxcooling.com](http://spxcooling.com)

TECH-NC-16A | ISSUED 08/2016  
COPYRIGHT © 2016 SPX CORPORATION

In the interest of technological progress, all products are subject to design  
and/or material change without notice.

